



---

---

---

*Read this instruction manual before using this appliance.*

*Lea el manual de instrucciones antes de usar esta máquina.*

*Lire attentivement les instructions du manuel avant d'utiliser la machine.*

*Lesen sie die vorliegenden Anweisungen vor Inbetriebnahme des Geräts aufmerksam durch.*

# *HVO* **SUMMIT** **S** Series

**Advanced SPRAY Cleaning Technology**

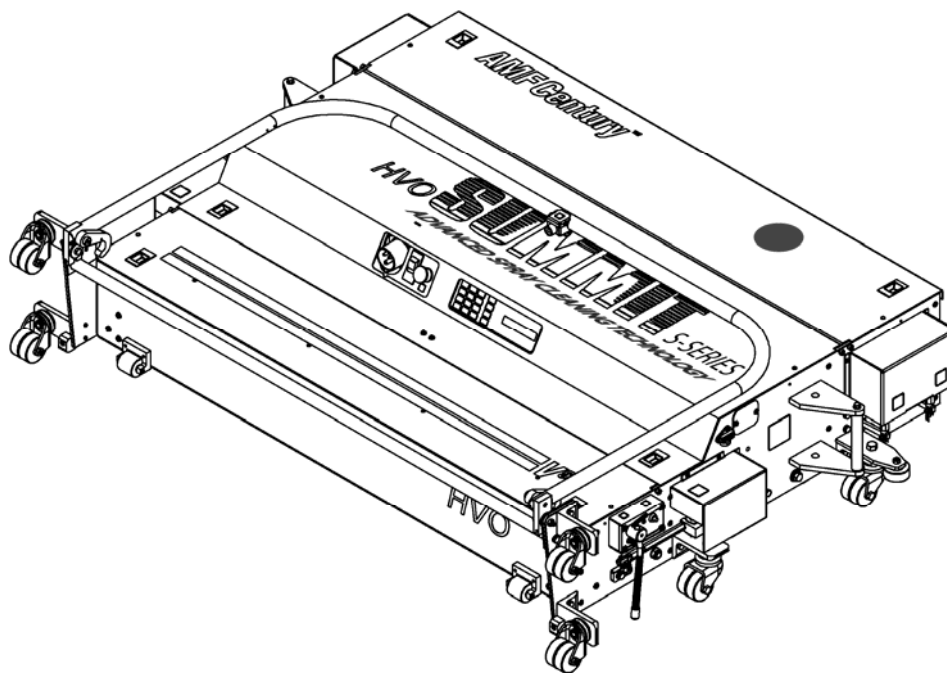

# **OPERATION, SERVICE, AND PARTS MANUAL**



---

The HVO SUMMIT S Series

# Operation, Service, and Parts Manual

---

Copyright © 2007, QubicaAMF Bowling Products, Inc.  
All Rights Reserved

**QubicaAMF BOWLING PRODUCTS, INC.**  
**8100 AMF Drive**  
**Mechanicsville, Virginia 23111**





# **HVO Summit S Series**

## **Operation, Service, and Parts Manual - P/N 294-005-021**

### **Rev. B**

#### **Summary of Changes**

<u>Change No.</u>	<u>ECR No.</u>

#### **List of Effective Pages**

<u>Page</u>	<u>Change No.</u>	<u>Effective Date</u>
All	Original	01/26/07



# Table of Contents

<u>WARRANTY AND SERVICE POLICY</u> .....	1
<u>IMPORTANT SAFETY INFORMATION</u>	
English .....	3
Deutsch .....	5
Français .....	7
Español .....	9
<u>INTRODUCTION</u> .....	11
Specifications .....	12
<u>SECTION 1</u>	
Receiving and Handling .....	1-1
Use of Cleaners and Conditioners .....	1-1
<u>SECTION 2</u>	
Operation .....	2-1
Dash Controls .....	2-1
Preparing and Using the HVO SUMMIT S Series .....	2-5
HVO SUMMIT S Series Variability and Versatility .....	2-5
Cleaning System .....	2-7
Conditioning System .....	2-10
The HVO Foam Wicks .....	2-13
Accessories .....	2-14
<u>SECTION 3</u>	
Service and Repair .....	3-1
Lane Conditioning System .....	3-1
Buffer Brush Maintenance .....	3-2
Vacuum System Maintenance .....	3-7
Cleaner Flow System Maintenance .....	3-10
Cleaner Pad Maintenance .....	3-12
Waste System Maintenance .....	3-13
Periodic Lubrication .....	3-14
Drive Chain and Sprockets .....	3-14
Transfer Roller Drive Chains and Sprockets .....	3-14
Buffer Drive and Idler Assemblies .....	3-15
Vacuum Head and Cleaner Pad Slide Block Mounts .....	3-16
Electrical Repairs .....	3-16
Control Module .....	3-16
Speed Control Box .....	3-18
Reversing Trip Arm Switch .....	3-18
Fuse Block Assembly .....	3-19
Power Cord .....	3-20
Peak Performance .....	3-21
Clearing Clogged Nozzles .....	3-23

# Table of Contents (cont.)

## SECTION 4

Troubleshooting .....	4-1
-----------------------	-----

## LIST OF FIGURES

Figure 2-1, Cleaner Pad Operating Mechanisms .....	2-7
Figure 2-2, Cleaner Pad Assembly .....	2-8
Figure 2-3, Filling the Cleaner Tank .....	2-8
Figure 2-4, HVO SUMMIT S Series in the Operating Position .....	2-10
Figure 2-5, Starting the Machine down the Lane .....	2-13
Figure 3-1, RP-43 Pressure Adjusting Tool .....	3-5
Figure 3-2, Buffer Brush Pressure Adjustment .....	3-6
Figure 3-3, Vacuum Head Adjustment Linkage .....	3-8
Figure 3-4, Vacuum Head Curvature Adjustment .....	3-8
Figure 3-5, Cleaner Pad Adjustment Linkage .....	3-12
Figure 3-6, Cleaner Pad Assembly .....	3-13
Figure 3-7, Lubricating the Buffer Idler Assembly .....	3-15
Figure 3-8, HVO SUMMIT S Series Control Module and Speed Control Box .....	3-17
Figure 3-9, Reversing Trip Arm Assembly .....	3-19
Figure 3-10a, Pivoting Fuse Holder .....	3-19
Figure 3-10b, Fuse Replacement .....	3-19
Figure 3-11, Oil Tank Linkage Adjustment .....	3-22

## APPENDIX A

Drawings and Part Numbers .....	A-1
---------------------------------	-----

### List of Drawings

294-002-413 – Oil Hood Assembly .....	A-2
294-002-423 – Electrical Hood Assembly .....	A-3
294-002-414 – Cleaner Hood Assembly .....	A-4
Body Assembly: Frame Assembly, Oil Tank Assembly .....	A-6
Frame Assembly .....	A-8
Body Assembly: Oil Tank Linkage Assembly .....	A-16
SA-3039, SA-3051 – Oil Solenoid Assembly, 110V & 240V .....	A-18
294-002-064 – Oil Tank Assembly Configuration .....	A-20
SA-0210 – Oil Tank Assembly .....	A-22
294-002-020 – Oil Tank Assembly, 10” HVO .....	A-24
294-002-070 – Transfer Roller Assembly .....	A-26
294-002-350, 294-002-270 – Buffer Motor Assembly, 110V & 240V .....	A-28
SA-1182 – Brush Tube Assembly .....	A-29
SA-6516R – Idler Assembly, Right .....	A-30
SA-1105 – Buffer Drive Assembly .....	A-32
SA-1106 – Buffer Idler Assembly .....	A-33



# Table of Contents (cont.)

SA-1227 – Oil Fill Bottle -----	A-34
Body Assembly: Brush, Cleaner Pad, Transfer Roller, Vacuum Head, Waste Tank ----	A-36
Front Plate Assembly, Front View -----	A-38
Front Plate Assembly, Rear View -----	A-40
Cleaner Tank Assembly -----	A-42
Filter Mount Assembly -----	A-44
SA-9032 – Vac-Head Assembly -----	A-46
SA-0256 – Cleaner Pad Assembly -----	A-48
SA-0321 – Vacuum Head Slide Block Mount Assembly -----	A-50
294-002-482 – Cleaner Tray Mount Assembly, Right -----	A-52
294-002-481 – Cleaner Tray Mount Assembly, Left -----	A-54
SA-1129 – Waste Tank Assembly -----	A-56
SA-1101 – Vacuum Hose Assembly -----	A-57
Base Plate Assembly: Drive Motor, Buffer Motor, Drive Shaft -----	A-58
SA-0259, SA-0291 – Drive Motor Assembly 110V & 240V -----	A-60
SA-0279 – Drive Shaft Assembly -----	A-62
SA-1205 - Counter Wheel Assembly -----	A-64
Base Plate Assembly: Control Box, Speed Control Box, Dash -----	A-66
294-002-421 – Dash Assembly -----	A-68
294-002-238 – Fuse Block Assembly -----	A-70
SA-1049 – Shut Off Arm Assembly -----	A-72
SA-1186 – Spring and Cap Assembly -----	A-72
294-002-419 – Centering Guide Plate Assembly -----	A-73
294-002-136 – Trip Arm Assembly -----	A-74
Final Assembly -----	A-76
294-002-416 – Handle Assembly -----	A-78
294-002-359 – 110V Power Cord Assembly -----	A-80
294-002-250 – 220V Power Cord Assembly -----	A-80
RP-43 – Buffer Pressure Adjusting Tool -----	A-81
HVO SUMMIT S Series Wiring Diagram, 110 / 120 Volt -----	A-83
HVO SUMMIT S Series Wiring Diagram, 220 / 240 Volt -----	A-84

## INDEX

Part Numbers -----	A-85
--------------------	------

This page intentionally left blank.

## **WARRANTY AND SERVICE POLICY**

If any defects in material appear during the 12 months after installation, the defective part will be repaired or replaced, at QubicaAMF Bowling's option, without charge to the customer for parts. The customer must assume all other costs in making the repair or replacement.

**NORMAL MAINTENANCE AND ADJUSTMENTS ARE THE RESPONSIBILITY OF THE CUSTOMER AND ARE NOT COVERED UNDER THE TERMS OF THIS WARRANTY.**

QubicaAMF Bowling Products, Inc. reserves the right to change the design of any product, but assumes no responsibility to incorporate such design changes on products already sold.

This warranty applies only to new products and extends only to the original purchaser. This warranty shall not apply to any machine repaired or altered in any way outside of our own factory-authorized service station and/or distributor, or where parts, other than QubicaAMF Bowling-approved parts, have been installed in the machine, or where the machine has been subject to misuse, negligence, accident, or abuse. QubicaAMF Bowling Products, Inc. reserves the right to inspect and make the final decision on any claim under this warranty that it deems questionable.

Under no circumstances shall the seller or manufacturer be liable for loss of profits or other direct or indirect costs, expenses, losses, or damages arising out of product design or defects in, or failure of, parts.

During the warranty period, parts that are faulty due to material or workmanship will be repaired or replaced free of charge only if the defective part is properly identified and returned for credit. A Product Trouble Report & Return Authorization should be completed, including a description of the problem, and the completed form should accompany the returned part. A Return Authorization number must be obtained from QubicaAMF Bowling Products, Inc. prior to returning any items. Identify the returned part by attaching a tag containing your bowling center's name, the part name, and part number.

The above warranty is exclusive: THERE ARE NO IMPLIED WARRANTIES, INCLUDING MERCHANTABILITY AND FITNESS FOR USE, beyond those expressly made herein.

This page intentionally left blank.



## IMPORTANT SAFETY INFORMATION

**WARNING!** The following basic safety-related items must be followed in order to ensure the safe operation of your lane machine. Failure to follow these precautions could result in serious personal injury, damage to the lane machine, or both.

- Read this instruction manual before using this appliance.
- This lane machine is very heavy. Obtain the assistance of a second person when transferring the machine between the operating and storage positions. Exercise care to prevent the machine from tipping when moving the machine while it is in the upright position.
- **ALWAYS** operate the lane machine on a dedicated and grounded electrical circuit of the proper voltage.
- Inspect the power cord prior to each use.
- **DO NOT** allow the lane machine to run over the power cord.
- Unplug and inspect the power cord for damage if the machine runs over the power cord. Should the power cord become entangled in the machine, unplug the power cord from the bowling center's electrical receptacle before attempting to clear the power cord from the machine.
- **DO NOT** operate this machine with a damaged power cord or plug.
- **DO NOT** use any other extension cord in place of, or in addition to, the one provided.
- Disconnect the power cord when cleaning, replacing parts, or performing maintenance.
- **DO NOT** operate the lane machine on a lane when someone is working on the lane or in the vicinity of the pinspotter.
- **DO NOT** operate the lane machine with a hood assembly open or removed except when required to make adjustments.
- **DO NOT** use flammable or toxic materials in the lane machine. Use only cleaners and conditioners specifically formulated for use by the bowling industry.
- **DO NOT** use the machine to pick up hazardous substances or for any purpose other than for cleaning and conditioning a bowling lane surface.
- Avoid splashing liquid when filling the cleaner tank and oil tanks. Follow all instructions and precautions on the product label. In case of eye contact, flush with water for 15 minutes.

- **DO NOT fill the oil tanks on or near the approach. Conditioner spilled on the approach presents a hazard to the bowler.**
- **Turn off the machine if foam or liquid issues from the vacuum exhaust.**
- **Be aware of the possibility of the machine continuing onto the approach when it returns to the foul line. Stay out of the path of machine travel when the machine is approaching the foul line.**
- **DO NOT wear loose personal items such as neckties, necklaces, bolos, or long hair around rotating machinery.**
- **Keep hands away from solenoid linkages, gears, chains, and belts. These components can pose a severe pinching hazard.**
- **Exercise caution whenever the hoods are open or when making adjustments. Some components may become hot during use.**
- **Never perform lane maintenance with the rear hood open. The rear hood contains a hold-down bar that is designed to keep the oil tanks in place during both operation and storage, yet allow easy tank removal when necessary.**
- **DO NOT modify the machine's wiring except as specified in QubicaAMF Bowling-supplied publications.**
- **DO NOT use or store the lane machine outdoors in wet conditions.**
- **DO NOT leave the machine unattended during machine maintenance or setup operations with the interlock key installed.**
- **Use only brushes supplied with this appliance or those supplied by the manufacturer for use in this machine.**
- **Ensure all of the machine's doors are closed and latched before placing the machine in the storage position.**



## **Wichtige Sicherheitsanweisungen!**

**Warnung!** Die nachfolgend beschriebenen grundlegenden Sicherheitsanweisungen müssen befolgt werden, um die sichere Inbetriebnahme ihrer Bahnenreinigungsmaschine zu gewährleisten. Die Nichtbefolgung der Maßnahmen kann zu Unfällen und Beschädigungen der Maschine führen.

- Lesen sie die vorliegenden Anweisungen vor Inbetriebnahme des Geräts aufmerksam durch.
- Die Bahnenreinigungsmaschine ist sehr schwer. Nehmen sie die Hilfe einer zweiten Person in Anspruch, wenn sie die Maschine bewegen. Achten sie darauf, daß die Maschine, wenn sie sich in aufrechter Position befindet und bewegt wird, nicht umfällt.
- Die Bahnenreinigungsmaschine muß **IMMER** an einer geerdeten Stromleitung angeschlossen werden, die über die angemessene Voltzahl verfügt.
- Überprüfen sie vor jeder Inbetriebnahme das Anschlußkabel.
- Achten Sie darauf, daß die Bahnenreinigungsmaschine **NICHT** über das Anschlußkabel fährt.
- Ziehen sie das Anschlußkabel aus der Steckdose und überprüfen sie es, falls die Maschine doch über das Anschlußkabel gefahren sein sollte. Wenn sich das Anschlußkabel in der Maschine verwickelt hat, muß es zusätzlich auch vom elektrischen Anschluß der Bahnenreinigungsmaschine entfernt werden, bevor es entwirrt wird.
- Nehmen sie die Maschine mit einem beschädigten Kabel oder Anschluß **NICHT** in Betrieb.
- Benutzen Sie **NUR** das zur Verfügung gestellte Verlängerungskabel. Es darf weder ersetzt, noch darf ein zusätzliches Kabel eingesetzt werden.
- Das Anschlußkabel muß bei der Reinigung, dem Austausch von Geräteteilen und der Wartung aus der Steckdose gezogen werden.
- Nehmen sie die Bahnenreinigungsmaschine **NICHT** in Betrieb, wenn Arbeiten auf der Bahn oder in der unmittelbaren Nähe des Pinabtasters vorgenommen werden.
- Nehmen sie die Bahnenreinigungsmaschine **NICHT** bei geöffneter oder entfernter Abdeckung in Betrieb, es sei denn, sie nehmen Einstellungsänderungen vor.
- Benutzen sie in der Bahnenreinigungsmaschine keine brennbaren oder giftigen Materialien. Verwenden sie nur Reinigungs- und Pflegemittel, die speziell für die Bowlingindustrie hergestellt wurden.

- **Benutzen sie die Maschine NICHT dazu, um giftige Substanzen zu entfernen. Sie dient ausschließlich zur Reinigung und Pflege von Bowlingbahnoberflächen.**
- **Achten sie darauf, daß beim Füllen des Reinigungsmittel- und Öltanks KEINE Flüssigkeit verschüttet wird. Befolgen sie die Anweisungen und Vorsichtsmaßnahmen auf dem Produktetikett. Bei Augenkontakt, Augen 15 min. lang mit Wasser spülen.**
- **Füllen sie den Öltank NICHT im Zugangsbereich der Bahn auf. Verschüttetes Pflegemittel stellt eine Gefahr für die Bowler dar.**
- **Stellen sie die Maschine ab, wenn Schaum oder Flüssigkeit aus der Vakuümöffnung austritt.**
- **Berücksichtigen sie die Möglichkeit, daß die Maschine bei der Rückkehr zur Foullinie in den Zugangsbereich der Bowlingbahn eintritt. Bleiben sie außerhalb des Maschinenwegs, wenn sie sich der Foullinie nähert.**
- **Tragen sie in der Nähe der arbeitenden Maschine KEINE herabhängenden Kleidungs- oder Schmuckstücke wie z.B. Krawatten oder Halsketten und binden sie langes Haar zusammen.**
- **Berühren sie keine elektromagnetischen Verbindungen, Zahnräder, Ketten oder Riemen. Sie stellen eine Verletzungsgefahr dar.**
- **Bei geöffneter Abdeckung oder bei der Änderung von Einstellungen muß mit Vorsicht an dem Gerät gearbeitet werden, da einige Bestandteile während der Benutzung heiß laufen.**
- **Eine Wartung der Bahn darf NIEMALS mit geöffneter hinterer Abdeckung durchgeführt werden. An der hinteren Abdeckung befindet sich eine Stange, die dazu dient, die Öltanks während der Benutzung und Lagerung der Maschine auf ihrem Platz zu halten und bei Bedarf das leichte Entfernen der Tanks zu ermöglichen.**
- **Die Kabel der Maschine dürfen NUR gemäß den von QubicaAMF Bowling herausgegebenen Anweisungen verändert werden.**
- **Die Maschine auf keinen Fall im Freien bei feuchten oder regnerischen Wetterbedingungen lagern oder benutzen.**
- **Die Maschine darf während ihrer Wartung oder Einstellung mit Benutzung des Sperrschlüssels nicht unbeaufsichtigt gelassen werden.**
- **Benutzen sie nur die mit diesem Gerät gelieferten oder vom Hersteller für dieses Gerät gelieferte Bürsten.**
- **Stellen sie sicher, daß alle Türen der Maschine geschlossen und verriegelt sind, bevor sie abgestellt wird.**





## CONSIGNES DE SECURITE

**ATTENTION!** Les instructions de sécurité de base suivantes doivent être suivies dans l'ordre afin d'assurer une utilisation sûre de votre machine à huiler. Tout manquement à ces précautions peut entraîner des blessures ou des dommages à la machine, voire même les deux.

- Lire attentivement les instructions du manuel avant d'utiliser la machine.
- Cette machine est très lourde. Aussi, si nécessaire, demander l'assistance d'une seconde.
- personne pour le passage à la position de huilage et de remplissage. De même, faire attention aux chocs lors du déplacement de la machine.
- Toujours brancher la machine sur une prise prévue à cet effet avec une mise à la terre correcte et une protection suffisante. S'assurer que la machine est bien sous le voltage approprié.
- Vérifier l'état du cordon d'alimentation avant chaque utilisation.
- Ne pas faire passer la machine sur le cordon d'alimentation.
- Débrancher et inspecter le cordon d'alimentation si la machine passe sur le cordon. Si celui-ci s'est emmêlé sous la machine, débrancher d'abord la prise au mur puis la prise de la machine.
- Ne pas utiliser la machine avec un cordon ou une prise en mauvais état.
- Ne pas utiliser un autre type de cordon d'alimentation que celui fourni avec la machine.
- Débrancher la machine lors des opérations de maintenance.
- Ne pas utiliser la machine sur les pistes où le mécanicien travaille, ou à proximité des machines.
- Ne pas utiliser la machine sans capot ou capots ouverts sauf si la maintenance le nécessite.
- Ne pas utiliser d'autres produits que ceux préconisés pour le dégraissage et le huilage.
- Ne pas utiliser la machine pour autre chose que le conditionnement des pistes.
- Nettoyer toutes projections d'huile ou de dégraissant lorsque vous remplissez les réservoirs. En cas de contact avec les yeux, rincer abondamment à l'eau pendant 15 minutes.
- Ne pas remplir les réservoirs d'huile sur ou à proximité des approches : des

**résidus d'huile pouvant être dangereux pour les joueurs.**

- **Ne pas rester sur le trajet de la machine lorsque celle-ci revient vers la ligne de faute.**
- **Mise en garde particulière pour les porteurs de colliers, vêtements amples ou cheveux longs à proximité de la machine sous tension.**
- **Ne pas mettre les mains sur ou à proximité des solénoïdes, des moteurs, des chaînes ou des courroies, ces éléments pouvant causer de sévères blessures.**
- **Faire attention lors de la maintenance avec les capots ouverts, certains éléments pouvant chauffer lors de l'utilisation.**
- **Ne pas utiliser la machine avec le capot arrière ouvert car ce capot est doté d'une barre permettant d'appuyer sur les réservoirs d'huile pour les maintenir en place lors de la manipulation de la machine.**
- **Ne pas modifier le câblage de la machine sauf spécification contraire dans les bulletins techniques fournis par QubicaAMF.**
- **Ne pas utiliser et stocker la machine dans des conditions humides.**
- **Ne pas laisser la machine en attente lors de la maintenance avec la clé de verrouillage insérée.**
- **N'utiliser que les brosses préconisées par le fabricant.**
- **S'assurer que tous les capots sont fermés et verrouillés avant de mettre la machine en position de remplissage.**



## **NORMAS DE SEGURIDAD IMPORTANTES**

**¡Atención!** Para la correcta utilización de la máquina de pistas deben seguirse las siguientes normas básicas de seguridad. De lo contrario se pueden producir importantes daños personales o en la máquina, o ambos.

- Lea el manual de instrucciones antes de usar esta máquina.
- Esta máquina es muy pesada, muévanla entre dos. Tenga cuidado de que no vuelque al ponerla en posición vertical.
- Maneje **SIEMPRE** la máquina en un circuito eléctrico con toma de tierra y adecuado voltaje.
- Inspeccione el cable antes de cada uso.
- No ponga la máquina encima del cable.
- Desenchufe e inspeccione el cable si la máquina está por encima del mismo. Si el cable se enreda, desenchufelo de la corriente antes de intentar desenredarlo.
- No maneje la máquina si el cable, la clavija o el enchufe están dañados.
- No use otro cable (o alargadera) distinto al original.
- Desconecte la máquina de la corriente cuando realice labores de mantenimiento, cambio de piezas o limpieza.
- No utilice la máquina en una pista donde haya alguien trabajando o cerca de otra máquina.
- No utilice la máquina con la tapa abierta excepto cuando se requiera para realizar ajustes.
- No utilice productos tóxicos e inflamables en la máquina. Utilice sólo productos acondicionadores y limpiadores específicos.
- No utilice la máquina para recoger sustancias o para otros propósitos distintos al de limpieza y acondicionamiento de pistas.
- Cuando llene el depósito de aceite, tenga cuidado de no salpicar. Siga todas las instrucciones y precauciones que figuren en la etiqueta del producto. En caso de contacto con los ojos, lávelos con agua durante 15 minutos.
- No llene el depósito cerca del “approach” ya que puede representar un peligro para los jugadores.
- Apague la máquina si se vierte algún líquido.

- **Recuerde que la máquina puede continuar por el “approach” cuando llega a la línea de falta. Permanezca fuera del paso de la máquina cuando ésta se aproxime a la línea de falta.**
- **Al manejar la máquina, no utilice prendas holgadas, ni colgantes, ni lleve el pelo suelto.**
- **Mantenga las manos fuera de solenoides, engranajes, cadenas y correas. Estos componentes pueden producir daños serios.**
- **Sea prudente siempre que trabaje en la máquina, algunos componentes se calientan cuando están en uso.**
- **No realice el mantenimiento de pistas con la tapa trasera abierta. Esta tapa contiene un mecanismo diseñado para mantener los depósitos en su sitio tanto si la máquina está activa como inactiva, además de permitir una fácil reposición de los depósitos cuando es necesario.**
- **No modifique el cableado de la máquina excepto como lo indique el manual de instrucciones.**
- **No utilice ni guarde la máquina a la intemperie o en ambiente húmedo.**
- **No deje la máquina desatendida durante su funcionamiento o fije las funciones con el sistema que lleva incorporado.**
- **Utilice sólo los accesorios provistos con este aparato.**
- **Asegúrese de que todas las tapas de la máquina están cerradas y bloqueadas antes de colocarla en posición de almacenamiento.**

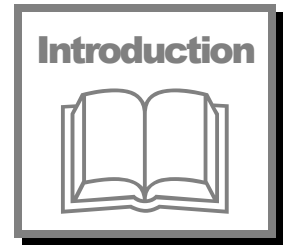

## HVO SUMMIT S Series

### Operation, Service, and Parts Manual

**T**he **HVO SUMMIT S Series** is a total lane maintenance machine designed to perform both lane stripping and conditioning functions and is capable of applying more conditioner in less time than any other lane conditioning machine. The HVO SUMMIT S Series is capable of simultaneously stripping and conditioning the lane – saving time while providing consistent lane conditions. Additionally, the versatile HVO SUMMIT S Series can be used as a stripping machine only or as a conditioning machine only, and can store up to 20 user-customizable lane conditioning programs. The HVO SUMMIT S Series offers many state-of-the-art operating features including features that are exclusive to the HVO SUMMIT S Series.

The HVO SUMMIT S Series wets the surface of the bowling lane by the use of three spray nozzles. The same foam pad and grey cloth used by the original HVO Summit is used to agitate the cleaner into the oil. This pad is wetted by the same detergent cleaning solution in the storage container and by the sprayed-on cleaner on the lane. The HVO SUMMIT S Series then dries the lane by using a vacuum head powered by an electrically operated vacuum motor. The lane is dry as soon as the vacuum head passes over the lane surface. **Use only detergent cleaners manufactured specifically for use by the bowling industry.**

The HVO SUMMIT S Series conditions the lane surface with lane dressing by the use of a buffer brush that moves up and down by solenoid action to engage the brush against the lane surface. Forward only, reverse only, and double oiling options are offered. In addition to the standard oiling distances, single pass, double pass, and a short run capability are also available.

# INTRODUCTION

The HVO SUMMIT offers the following features:

- $V^1$  variable Flow Tanks and Wicks
- $V^2$  variable Speed Oil Transfer Roller
- $V^3$  variable Machine Speed
- $V^4$  variable Distance and Position Tank Sections
- $V^5$  variable Distance Dressing Buffer

The HVO SUMMIT S Series offers 20 fully programmable lane conditioning programs for oiling only, stripping only, or oiling and stripping simultaneously. The HVO SUMMIT S Series also introduces the **New Improved Advanced Spray Cleaning Technology**. The *HVO SUMMIT S Series Programming Guide* (294-005-022) explains all of the software features and provides instructions for using the keypad and display to customize the machine's built-in lane conditioning programs as well as to set other machine operating parameters. The lane conditioning programs can also be customized using *Century Programmer for Windows*® (CPWin) to download program information directly from your computer.

## Specifications

Electrical	Single phase, 208 - 250V~, 50/60 Hertz Single phase, 100 - 120V~, 50/60 Hertz
Main Power Circuit Breaker	220 / 240V~, 12 Amps 110 / 120V~, 24 Amps
Overcurrent Protection	Each motor and solenoid is individually protected against an overcurrent condition either by a thermal overload protection device or by individual 5 x 20-mm fuses.



**Note: It is imperative that the HVO SUMMIT S Series is operated with a dedicated and grounded electrical circuit of the proper voltage.**

Weight	350 Pounds (159 kg)
Dimensions	Width 57 inches (144.8 cm) Height 12½ inches (31.75 cm) [sitting on casters & handle folded] Depth 43 inches (109.2 cm) [handle folded]
Cleaner Tank Capacity	180 Ounces (5.32 liters)
Waste Tank Capacity	250 Ounces (7.39 liters)

## Receiving and Handling

Unpack the unit and remove all packing material. Pay particular attention to any tags that may be attached to the interior or exterior of the machine and accessories. Follow any instructions on the tags. An QubicaAMF Bowling Products, Inc. representative will assist in the installation and provide information on the use of your new lane machine.

Carefully inspect your unit to ensure that there has been no damage in shipment. In case of damage, be sure to contact the transporter of your unit immediately and file a freight damage claim. QubicaAMF Bowling Products, Inc. is not responsible for damage incurred during shipment.

Unpack the cleaner pad storage container supplied with your HVO SUMMIT S Series machine. Remove the cleaner pad from the lane machine and place the cleaner pad assembly into the storage container. Fill the storage container with the cleaning solution (at its recommended dilution) to be used in the machine. Use only detergent lane cleaners manufactured specifically for use by the bowling industry. The cleaner should be diluted according to the manufacturer's recommendations, but at least by three parts of water to one part of cleaner. **Whenever the machine is not in use, store the cleaner pad assembly immersed in cleaning solution in the storage container to prevent the foam pad from drying out.**

## Use of Cleaners and Conditioners

Special care should be taken when filling the cleaner tank with cleaner and the oil tanks with oil. The use of a funnel with filtration screen of the appropriate size and material for the cleaning solution being used and an oil fill bottle designed to automatically fill the oil tanks to the correct level is the proper way to fill the tanks without spilling liquids into the machine. Special care should be taken to avoid spilling anything into or onto all motors, solenoids, switches, and wiring. A filter funnel and an oil fill bottle are included with the HVO SUMMIT S Series.

There are three areas of concern when using lane cleaning or dressing liquids in the HVO SUMMIT S Series. These areas are flammability, toxicity, and compatibility.



**CAUTION**

**DO NOT use flammable or toxic materials in the lane machine. Use only cleaners and conditioners specifically formulated for use by the bowling industry.**

**DO NOT fill the oil tanks on or near the approach. Conditioner spilled on the approach presents a hazard to the bowler.**

Additionally, there are a few other operating practices that should be followed whenever using the lane machine, as outlined below.

When selecting a product for use as a lane cleaner, the manufacturer or his representative should be contacted. They will provide information relative to the use and safety of that product.

Material Safety Data Sheets (MSDS) are available for all QubicaAMF Bowling-supplied cleaning and conditioning solutions.

Use of common sense and industry experience are key factors that one should utilize when operating a lane conditioning machine. If you have any questions regarding the selection of cleaners and conditioners contact your QubicaAMF Bowling product distributor. Items regarding the operation of your HVO Summit S Series lane machine that are not covered in this manual should be directed to QubicaAMF Bowling Technical Support.



## Operation

**T**he **HVO SUMMIT S Series** retains the easy-to-operate design of QubicaAMF's other lane machines. Understanding the function of the machine's controls is all that is necessary to get started.

### Dash Controls

#### MAIN POWER CIRCUIT BREAKER

This combination ON/OFF switch and circuit breaker protects the machine from an overcurrent condition and acts as a backup current limiting device for the individually fused components.

#### POWER LIGHT (CE 240V only)

This green light, which is built into the main power circuit breaker, is illuminated whenever there is power available to the machine and the main power circuit breaker is closed.

#### BUFFER MOTOR PROTECTION

The buffer motor contains an integral thermal overload protection device that is designed to interrupt current to the buffer motor if the motor's winding temperature exceeds the manufacturer's limit. A manual reset button located on the side of the buffer motor below the vacuum motor is provided to allow the operator to restore power to the buffer motor following an appropriate cooling-off period. A manual reset prevents the motor from restarting unexpectedly.

# O P E R A T I O N

MANUAL REVERSE	This push button, when depressed momentarily, will reverse the direction of the machine from forward to reverse. It also disables all machine functions allowing the machine to return to the foul line with only the drive motor engaged. This can be especially useful as a lane recovery feature following a power failure or the machine becoming stuck on the lane (drive timeout).
COMPONENT FUSE PROTECTION	Most major electrical components (drive motor, solenoids, etc.) are individually fused to protect against an electrical fault. The fuse holders use 5 x 20 mm fuses.
LIQUID CRYSTAL DISPLAY (LCD)	The display screen consists of two lines of alpha-numeric characters used to provide information on the status of the machine and to allow the user to customize lane conditioning programs, security levels, and scheduling options. The HVO SUMMIT S Series can be easily programmed using the <i>HVO SUMMIT S Series Programming Guide</i> (294-005-022) to provide custom lane conditioning that is matched to each center's (or each lane's) unique requirements.
KEYPAD	The keypad is used to input menu selections and values for programming the operation of the lane machine. It is also used to select previously stored lane conditioning programs or to select any of the other menu functions.
DOWNLOAD CAPABILITY	Each machine is equipped with a standard RS232 serial communication port that can be used along with your bowling center's personal computer and the supplied software and communications cable to download additional lane conditioning programs to your HVO SUMMIT S Series lane machine.

## O P E R A T I O N

The HVO SUMMIT S Series can perform either a single pass or a double pass on each lane depending on the lane conditioning program selected, and it does this more efficiently than ever before by automatically changing speeds for different functions resulting in a time savings for every lane conditioned. The HVO SUMMIT S Series can function in more than one mode. It can be used:

A – As a simultaneous lane stripper and conditioner.

To accomplish this, the retrieved lane conditioning program should have the first and second pass oil options programmed as desired, and the stripping function engaged with FULL lane stripping selected.

B – As a lane conditioner and simultaneous back end stripper.

For this mode the machine should be set up with the retrieved lane conditioning program's first and second pass oil options programmed as desired, and the stripping function engaged with BACK lane stripping selected.

C – As a full lane or back end stripper - with no conditioning.

To select this mode of operation, the retrieved lane conditioning program should have the first and second pass oil options turned OFF, and the stripping function programmed ON with BACK, for back end stripping, or FULL, for full lane stripping, selected.

D – As a lane conditioner - with no stripping.

For this operation the retrieved lane conditioning program should have the first and second pass oil options programmed as desired with the stripping function turned OFF. During this operation, the retrieved program will automatically lift the buffer brush away from the lane at the selected buffing distance while the machine continues on for an additional six inches. This eliminates the traditional oil line caused when a buffer brush remains against the lane as a machine stops its forward travel.

## O P E R A T I O N

Whenever the buffer brush is programmed ON for the second pass in either forward only, reverse only, or double (both directions), the HVO SUMMIT S Series will automatically make a second pass. The buffer brush and oil engagement distances are selected during program editing to create the desired program. Your HVO Summit S Series lane machine is shipped with 20 factory-supplied lane conditioning programs loaded in the machine's memory. Instructions for creating and editing lane conditioning programs are contained in the *HVO Summit S Series Programming Guide* (294-005-022) and in the *Century Programmer Manual* (FM-0060) which were included with your lane machine. Use the HVO SUMMIT section of Century Programmer and use the appropriate selections. The HVO SUMMIT S Series needs to have cleaner at 100%, in the "IN OIL" and 100% or less in the "OUT of OIL". This has been preset for the factory defaults.

The HVO SUMMIT S Series multiple tank and wick design, independent oil tank control, special high volume output (HVO) oil tanks, and its double pass capability enable the machine to apply oil in numerous combinations of patterns and profiles.

Additionally:

- Buffer brush engagement against the lane is variable and independently programmable for both the forward and reverse directions of travel for each of the two machine passes.
- Wick engagement distances are variable and independently programmable for the different directions and passes.
- The oil transfer rate is variable and programmable for each direction and pass through the use of a variable speed transfer roller motor.
- The HVO SUMMIT S Series drive speed is also variable and programmable for high, medium, and low speeds for the machine's different functions (stripping, conditioning, traveling, etc.) resulting in a machine that is quicker and more versatile than ever before.

## Preparing and Using the HVO SUMMIT S Series

### HVO SUMMIT S Series Variability and Versatility

#### Note

**Lanes should be dusted before using this machine to maintain lanes!**

This latest generation lane machine, the **HVO SUMMIT S Series**, employs the HVO oiling system to achieve the desired conditioner distribution, and the new improved SPRAY cleaning and pad agitation system.

The first component of the HVO SUMMIT S Series oiling system is the variable distance buffer brush. The buffer brush can be programmed to be in contact with the lane surface for the desired distance of machine travel, and this distance can be different for the first pass forward, first pass reverse, second pass forward, and second pass reverse. The buffer brush lifts up off the lane surface at the end of the programmed distance. If the buffer brush is not adjusted properly, it may not contact the lane surface or only contact part of the lane and, as a result, will not lay down the desired oil pattern. A properly adjusted buffer brush can be programmed to build up an oil profile with the desired degree of lengthwise taper.

The second component of the HVO SUMMIT S Series oiling system is the variable speed oil transfer roller. For a given machine speed, the faster the transfer roller speed, and the higher the number of *units* of oil applied to the lane. The slower the transfer roller speed, the lower the number of *units* of oil applied. The oil transfer roller speed can be programmed to be different for the first pass forward, first pass reverse, and second pass forward and second pass reverse travel of the machine. This allows you to control the number of *units* of oil applied on each directional pass of the HVO SUMMIT S Series giving the user the ability to customize the oil profile to best suit each lane's unique conditions. The Summit's high volume output oil system's transfer roller is now 80% faster than previous QubicaAMF lane machines.

The third component of the HVO SUMMIT S Series oiling system is the variable distance and position dressing tanks and wicks. The six oil tanks are independently controllable. The two tanks in the middle are designated "CENTER" (left and right), the tanks on either side of the center tanks are designated "TRACK" (left and right), and the two outermost tanks are designated "OUTSIDE" (left and right). Currently, only the special 10-inch HVO oil tanks are available for the two CENTER positions. Other tanks may be available in the future. The outside and track dressing tanks and foam wicks can be replaced with tanks and foam wicks of different sizes to suit your needs at any time. This allows you to select the board position on the lane where a change in dressing distribution will take place. A different

outside and track width dimension can be selected for the left versus the right side of the lane. Thus, the left to right pattern of oil can be customized to obtain the desired cross-sectional profile. The only restriction is that the total length of the six tanks must equal 40 inches. A set of shims is included that can be used between the 10-inch HVO oil tanks and wicks where the wicks contact the transfer roller, to provide a variation in oil pattern across the width of the HVO tanks.

It might sometimes be desirable to apply new lane dressing over existing lane dressing after a lane or lanes have been bowled on for a while. In that case, the lanes should first be "read" with the Brunswick® Lane Monitor™ before being redressed. These graph readings will show the actual pattern of the lane dressing remaining. By creating the necessary program and selecting the necessary outside, track, and center dressing tank widths, "fill-in" programs can be accurately created.

The fourth component of the HVO SUMMIT S Series oiling system is the variable flow tanks and foam wicks. As describe earlier, oil flow from the foam wicks can be varied by varying the speed of the transfer roller. Additionally, oil flow can be adjusted by adjusting the pressure of the Foam wicks against the transfer roller. Generally, the more pressure the greater the oil transfer rate, but with the foam wick you will need to adjust the pressure so that you do not pinch off the flow. Thirdly, the wicks are available in different densities which translates into different oil application rates that can be used to achieve the desired oil pattern. Additionally, each oil tank can be adjusted independently of the other to achieve the desired oil pattern. It is recommended that you use the HVO Summits S Series supplied foam wicking material as it is more stable and has better durability. The use of third party foam wicks may degrade your performance and expectations.

The fifth component of the HVO SUMMIT S Series oiling system is the variable speed drive system. This system allows the user to program different drive speeds for the different conditioning functions: oiling, stripping, oiling and stripping, and traveling (traveling is machine movement without any oiling or stripping functions taking place). The system can be programmed to increase the oil transfer rate to accommodate a faster lane conditioning speed. It also features a variable, programmable cleaning solution flow rate for applying the proper amount of cleaning solution at any user-programmed stripping speed. This function allows setting different cleaning solution flow rates for stripping the lane in the conditioned area and in the back end area where less solution is needed. This results in fast, efficient, and consistent lane conditioning. However in spraying you regularly need 100% "IN OIL" and something less in "OUT of OIL". The spray is a cycle of 2 seconds, where you can control the time On or Off within the 2 second cycle.

## Cleaning System

1. Place the HVO SUMMIT S Series in the storage (upright) position.
2. Remove the cleaner pad from its storage container and squeeze the excess cleaning solution out of the pad using the convenient ridges that are molded into the container.
3. Install the cleaner pad in the lane machine. The cleaner pad linkages have locks (latches) on them to prevent the cleaner pad from moving vertically except when the solenoids have been engaged (see Figure 2-1).

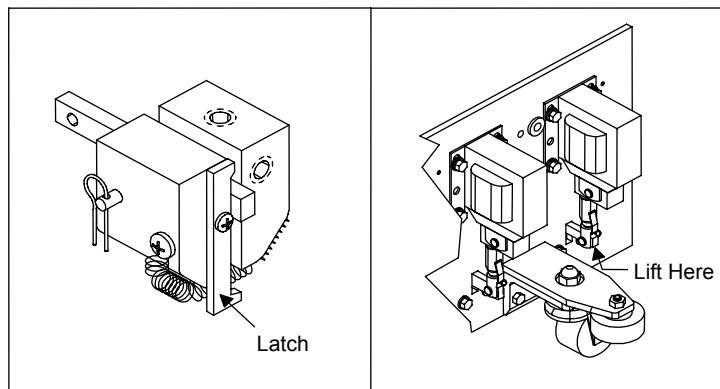

**Figure 2-1,** Cleaner Pad Operating Mechanisms

- a) Lift each cleaner pad solenoid linkage slightly by hand (see Figure 2-1) to release the locks and allow entry of the cleaner pad from the underside of the machine into its proper location. The cleaner pad should only fit into the machine one way. The row of closely spaced holes in the cleaner pad tray should be positioned toward the cleaner tank end of the machine. Ensure that the retaining springs snap into the notches on the underside of the cleaner pad assembly's end tabs.
- b) The foam cleaner pad is tapered. The thicker part of the pad should be positioned toward the dash end of the machine and the thinner part of the taper toward the cleaner tank end of the machine beneath the row of closely-spaced holes in the cleaner tray (see Figure 2-2).

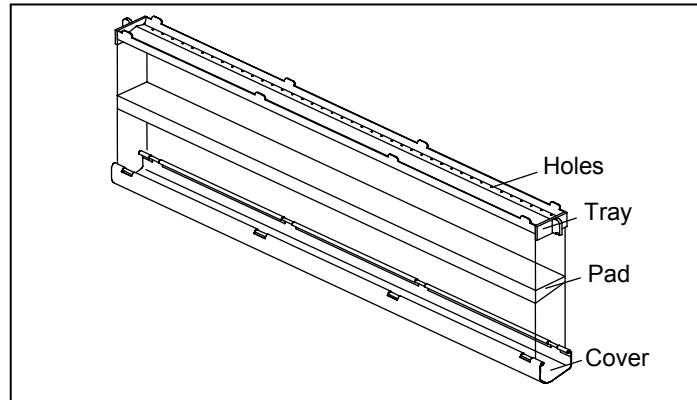

Figure 2-2, Cleaner Pad Assembly

4. Place the machine in the operating position, and fill the cleaner tank with cleaning solution. Use a cleaner specifically formulated for bowling center use, and mix according to the manufacturer's recommendations.



**CAUTION**

**Avoid splashing cleaner. Follow all instructions and precautions on the product label. In case of eye contact, flush with water for 15 minutes.**

- a) Use the filter funnel provided with your HVO SUMMIT S Series when filling the cleaner tank. (see Figure 2-3).
- b) Wipe up any cleaner that is spilled inside or outside the machine.
- c) The HVO SUMMIT S Series cleaner tank extends out of the hood for easier filling. This lid also has a vent hole to normalize the pressure due to pumping the fluid to the nozzles. After filling, replace the filler cap and tighten firmly.

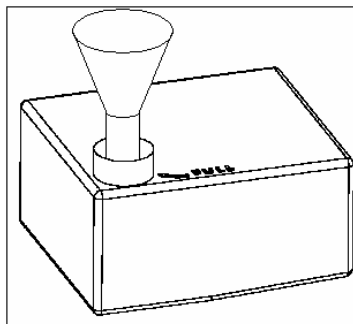

Figure 2-3, Filling the Cleaner Tank



The HVO SUMMIT S Series has three spray cleaning nozzles, and during machine use, are under a pressure ranging from 0 - 60 psig (0 to 4.757bar). However the flow, and therefore pressure, is generally at the lower end. While this pressure or spray is low, ejected liquid could present a hazard to the eyes, skin, and respiratory system. The degree of the hazard depends on the specific cleaning product being used. Consult the cleaning product's Material Safety Data Sheet (MSDS) for specific hazard information. It is a good practice to empty the waste tank whenever the cleaner tank is filled and at the completion of lane conditioning.

5. Whenever the lane machine is not in use, store the cleaner pad assembly in its storage container to prevent drying out the foam pad, which can become clogged with cleaner residue restricting cleaner flow through the foam. **If you do not store the cleaner pad submerged in its storage container, the useful life of the pad will be significantly reduced.**

**Note**

**Menu Function 96, Cleaner Presoak, can be used to adjust nozzle flow, if necessary. When this function is used, cleaning solution flows from nozzles for 30 seconds at a rate set by the user. Use this function well down the lane and then run a strip or strip and condition program to clean up the lane.**

The stripping distance and mode (FULL or BACK) are selected when the appropriate lane conditioning program is retrieved. These programs can be customized by the user to achieve the desired conditions. A higher cleaner flow rate is required for full lane stripping than for back end stripping. The cleaner flow rate is programmable and can be set according to the part of the lane to be stripped.

The machine's operating speed is a factor in determining the optimum cleaner flow rate to use. The drive motor operates on direct current supplied by the HVO SUMMIT S Series internal circuitry. Operating the lane machine on 50-hertz electrical power should have little effect on drive speed, and therefore, should not require the user to reduce the cleaner flow rate under these conditions.

6. To keep suds from being sucked into the vacuum motor, pour one to two ounces of defoamer into the waste tank before every lane cleaning session. You should empty the waste tank every time you fill the cleaner tank during a lane cleaning session and before you store the machine. The waste tank also has a line marked "MAX" and it should be emptied once the level of waste reaches that line.

Though a full waste tank will not leak when the machine is in the storage position, we recommend that you empty and clean the waste tank before storing the machine.

## Conditioning System

1. Place the HVO SUMMIT S Series in the operating position on the first lane to be maintained (see Figure 2-4).

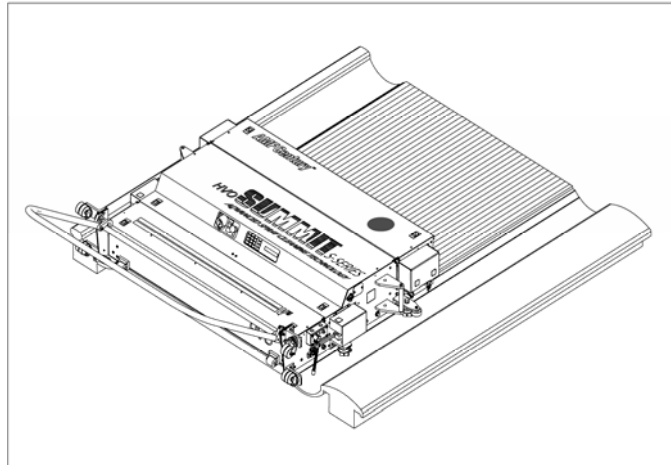

**Figure 2-4,** HVO SUMMIT S Series in the Operating Position on a Lane

2. Fill the oil tanks to the mark on the dipstick using the oil fill bottle so that all of the tanks have the same level of oil in them. If this is the initial fill, it may be necessary to allow the machine to sit for up to three hours to saturate the new wicks.

The oil tank dipsticks are marked to show the correct level. The amount of conditioner in the oil tanks should be kept as close as possible to the line on the dipstick. As conditioner is used, it should be replaced. How many lanes you get from a tank between fillings depends on the pattern you are applying. Therefore, check the oil tanks approximately every 10 to 20 lanes until you are confident in the number of lanes your lane conditioning program produces, and then fill to the mark on the dipstick as required.



### CAUTION

**Avoid splashing conditioner. Follow all instructions and precautions on the product label. In case of eye contact, flush with water for 15 minutes.**

An oil fill bottle is supplied with each machine to simplify filling the tanks. **There are a few do's and don'ts that must be followed for consistent results and to prevent overfilling the tanks.**

- Do NOT overfill the bottle. Fill to the bottle's shoulder only (28 oz), not to the fill line molded into the plastic bottle. Leaving a little extra air space in the neck will improve operation.
- Insert the bottle's nozzle into the tank's fill opening so that the nozzle's first shoulder rests on the lip of the tank opening.
- To fill an oil tank, place the palm of your hand on the bottom of the oil fill bottle and press down firmly. The nozzle will be depressed allowing conditioner to flow from the bottle into the tank. The bottle is designed to gravity feed into the tank and is supplied with an internal vent to prevent a vacuum from forming in the bottle. When the level of the conditioner in the tank reaches the tip of the nozzle, conditioner flow stops.
- Do NOT hold the bottle by the sides when filling the tank. This results in squeezing the bottle preventing proper equalization of pressure and can force excessive conditioner into the tank resulting in overfilling, spillage, and inconsistent application of conditioner to the lanes from fill to fill.



**Never fill the dressing tanks on the approach area. Conditioner spilled on the approach presents a hazard to the bowler. Any conditioner that the operator does spill (including any conditioner spilled into the machine) must be immediately wiped up, and the spilled area properly cleaned.**

3. Power up the HVO SUMMIT S Series.
  - a) Hook the loop of the cable support grip onto the spring-loaded hook on the side of the machine and attach the power cord's connector to the machine's connector plug. The cap on the cord's connector has a tab that fits into a cutout in the hood and is designed to help prevent the connector from being pulled loose.
  - b) Rotate the handle to the operating position and secure the power cord to the handle using the hook-and-loop cord strap.
  - c) Plug the power cord into a dedicated, grounded receptacle of the proper voltage.

## O P E R A T I O N

4. Prior to conditioning the first lane, saturate the buffer brush with conditioner as follows:
  - a) Place the machine in the operating position on the lane, select Menu Function 92 from the keypad, and press then START button twice. The transfer roller motor and buffer motor energize, and the dressing tanks engage against the transfer roller transferring oil from the wicks, to the roller, and into the brush. During saturation, the lane machine remains stationary at the head of the lane. The machine will continue to saturate the buffer brush until stopped by the operator. Do not run the saturate function for more than a few seconds.
  - b) To stop saturation, move the SHUT OFF ARM forward (see Figure 2-5).
5. Retrieve the lane conditioning program to be used to condition the lanes, and run that program on the first lane three times. This will ensure that the oil profile is consistent from lane to lane from the very first lane. For information about retrieving lane conditioning programs and other control functions, refer to the *HVO Summit Programming Guide*, 294005022.
6. Start the machine down the lane by pressing the handle or side START push button twice within a 2 to 3 second period. As the machine starts to move away from the foul line, lower the handle so that it clears the masking when the lane machine approaches the pin deck (see Figure 2-5).
7. Following each use of the lane machine, the buffer brush assembly should be removed from the lane machine and thoroughly cleaned using a rag or towel wet with the same conditioner used to dress the lanes. Do not use a hot air gun to dry the brush, as this can damage the bristles. The compartment in the machine that the buffer brush assembly fits into should be thoroughly cleaned before reinstalling the buffer brush assembly.

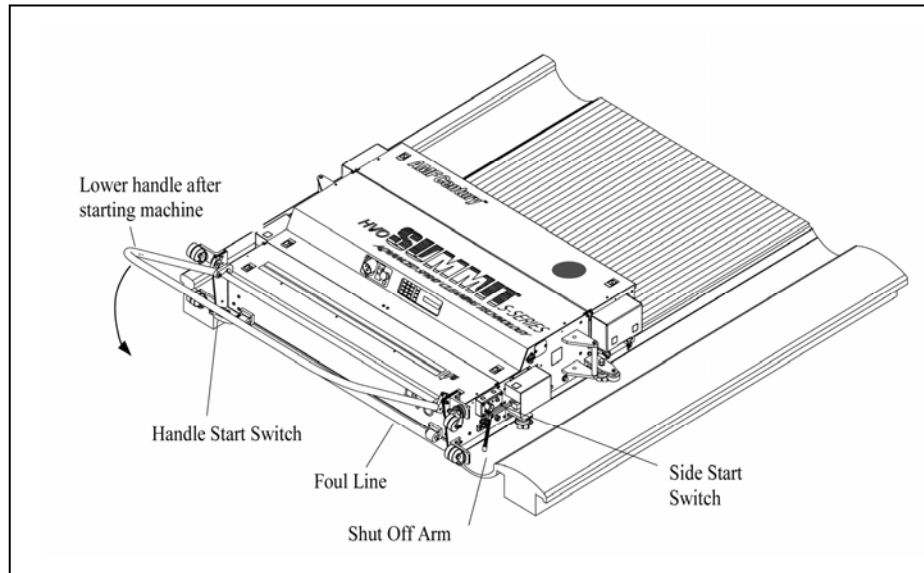

**Figure 2-5, Starting the Machine down the Lane**

### **The HVO Foam Wicks**

The foam wicks are a superior development. They last longer, and flow more consistently, especially in the high volumes of oil being applied today. Your machines will come with the same foam material in each tank.

### **Wicking oil in general**

Be aware that switching to a different type of wick may require adjustment of your existing lane conditioning programs in order to continue applying the same amount of oil to the lane surface.

The ambient temperature can also have an effect on the amount of conditioner being applied to the lane. Generally, the higher the temperature, the more conditioner applied. This occurs because as temperature rises, the conditioner's viscosity decreases causing it to "flow" at an increased rate.

# O P E R A T I O N

Other factors can lead to oil patterns changing over time. As a set of wicks becomes embedded with dirt from use, its ability to transfer conditioner from the tanks to the transfer roller diminishes. Clean the wicks daily. Approximately every two to three months, rotate the wicks so that the back side of the wick contacts the transfer roller, and replace the wicks every four to six months. These are general recommendations, and the frequencies should be increased as your specific conditions warrant. If after replacing a set of wicks the amount of conditioner increases to the point that too much conditioner is being applied, try reducing the transfer roller speed, in the first pass forward direction only, by approximately 15% (The exact amount is determined by trial and error). This can also be done for increased application rates that are due to a rise in ambient temperature.

The HVO SUMMIT S Series two center tanks are of a high volume output (HVO) design. These high volume, high capacity tanks are unique to the HVO SUMMIT S Series of lane machines, and not only hold more conditioner (so they don't need to be refilled as often), but also provide an increased rate of conditioner transfer to the wicks.

## Accessories

The following is a list of items and part numbers for accessories that are included with your HVO SUMMIT S Series. The list does not include any documentation or cleaning and conditioning chemicals that are furnished with the machine.

<b>Description</b>	<b>Part No.</b>	<b>Description</b>	<b>Part No.</b>
Buffer Pressure Adjusting Tool	RP-43	Funnel – Large w/screen	RP-115
Dressing Tank Pressure Gauge	RP-72A1	Funnel – Long Stem	RP-116
Programming Cable – 25'	SA-0289B	Storage Container Assembly	SA-0305
Power Cord - 240V Machine only	294-002-250	Oil Fill Bottles	SA-1227
Power Cord - 110V Machine only	294-002-359	HVO Foam Wick Kit	612-551-001

## Service and Repair

The HVO SUMMIT S Series is designed to make maintaining the machine as simple as possible. Following good maintenance practices will ensure that you get consistent results while maximizing the life of components that are subject to wear. Simply keeping the machine clean, cleaning the buffer brush and cleaner pad, wiping up oil and cleaning solution spills, using the oil fill bottle and filter funnel, and storing the cleaner pad assembly in its storage container will go a long way toward getting the most out of your machine. The following subsections provide the information you will need for adjusting and maintaining your lane machine.



### CAUTION

**Except as required to perform specific maintenance items, unplug the HVO SUMMIT S Series before performing any maintenance or repair.**

## Lane Conditioning System

The oil tanks are the supply reservoirs for the lane oil. They should be filled to the level indicated on the oil tank dipstick using the oil fill bottle. This depth should be checked periodically during use, but at least after each lane maintenance session.

Lane conditioner is removed from the oil tanks by the oil tank wicks. Different size wicks corresponding to the various tank sizes are available. The different tank sizes accommodate a variety of conditioners and lane dressing patterns used in the bowling industry today. The HVO SUMMIT S Series machine utilizes six separate dressing tanks and wicks. Clean the wicks daily, and replace them whenever they become excessively dirty or show a reduction in oil transfer ability. You may reverse the wicks (front to back) to extend useable life of the wick.

Compensation for the different types of lane dressings is accomplished by the use of a variable speed oil transfer roller. The variable speed transfer roller motor drives the transfer roller. The oil transfer rate is proportional to the

transfer roller speed. The transfer roller speed is variable and programmable for each direction of machine travel on each pass of the machine. When a dressing tank wick is engaged against the oil transfer roller and the roller is turning, oil is removed from the dressing tank wick and transferred to the buffer brush. Keep the transfer roller clean and free of contaminants and wipe it down at the completion of each machine use.

The amount of pressure that the wicks exert against the transfer roller affects the conditioner transfer rate. Testing was performed using the factory-supplied lane conditioning programs, and in general, this pressure should be from 'B' to 'D' on the RP-72A1 dressing tank pressure gauge, which is supplied with your lane machine. To set oil tank pressure, use Menu Function 93, *Adjust Oil*, to engage the wicks against the transfer roller and then slide the forked vinyl section of the pressure gauge between the wick and the transfer roller. Observe the reading on the gauge while removing the pressure gauge using a straight pull with constant speed. Hold only the metal part of the gauge during removal. The pressure gauge is forked so that it can straddle the oil tank linkage while taking this reading. To adjust this pressure, tighten or loosen (as required) the nut on the end of the oil tank linkage.

Too much pressure against the transfer roller can pinch the wick causing a significant reduction in oil transfer. When the lane conditioning program calls for the machine to stop conditioning, the oil tanks must be "kicked away" from the oil transfer roller. Excessive spring tension or a worn linkage can prevent this from happening.

Calibration of the conditioning system is the last item to be set by the operator. Do this after all other machine adjustments have been made. Calibration of the oil pattern consists of adjusting the actual oil pattern to match the expected oil pattern and is achieved by varying the speed of the oil transfer roller, adjusting the length of travel along the lane with the oil tank wicks engaged against the transfer roller, the width and position of the oil tank wicks, and the length of travel along the lane with the buffer brush in contact with the lane.

## **Buffer Brush Maintenance**

In order to assure the proper operation of the HVO SUMMIT S Series oiling system and to maximize the life expectancy of conditioning components, the following maintenance must be performed at the stated intervals. These steps are not a substitute for dusting the lanes prior to conditioning.

The buffer brush should be removed from the HVO SUMMIT S Series after each use and cleaned with a cloth that has been wet with the same conditioner



being used to dress lanes. The buffer brush should be thoroughly dried after it has been cleaned. Do not use a hot air gun to dry the brush.

The buffer brush will get dirty during use and will become worn over time. Operating the machine with a dirty buffer brush or with too much brush pressure against the lane will accelerate wear and shorten the brush's useful life. The life expectancy of the replaceable buffer brush is approximately 36 months. After that, the brush may be too worn, frayed, or dirty to properly apply conditioner to the lane.



**WARNING**

**Only approved lane cleaner should be used to deep clean the buffer brush assembly. Do not use any other chemical as this may damage your buffer brush fibers rendering it useless. Never use a hair dryer or similar heating device to dry the buffer brush after cleaner fluid cleaning. This heat could melt the fibers.**



**WARNING**

**This lane machine has been designed for use only with brushes specified by the machine's manufacturer. Fitting the unit with other brushes can adversely affect safety.**

To replace the buffer brush assembly:

1. Disconnect the power cord from the machine.
2. Place the machine in the storage position.
3. Slide the buffer brush assembly to the right towards the idler bearing, and pull out on the left end of the brush slightly.
4. Pull the buffer brush assembly away from the idler bearing socket until it disengages, and then remove the brush from the machine.
5. Lightly grease the spring-loaded end of the new buffer brush assembly.
6. Insert the new buffer brush assembly by reversing the actions of Steps 3 and 4.

On a weekly basis, clean the buffer brush as follows:

1. Remove the buffer brush from the machine.
2. Using a stiff-bristled hairbrush or a coarse comb, carefully but thoroughly clean the buffer brush's bristles. Clean the bristles by brushing or combing along the length of the buffer brush.

## S E R V I C E   A N D   R E P A I R

3. Keep the hairbrush or comb clean to avoid forcing dirt deeper into the brush's bristles.
4. When finished, wipe down the buffer brush with a clean rag dampened with conditioner.
5. Reinstall the buffer brush into the machine.

The buffer brush receives dressing from the transfer roller and applies the dressing to the lane surface. The buffer brush must be set against the lane with the proper pressure in order to obtain consistent oil patterns and to maximize the life of the lane machine's components. A pressure adjusting tool (RP-43) is included with each HVO SUMMIT S Series to provide the user with the means of accurately taking measurements and making adjustments. This adjustment must be done before calibrating the oil tank system.

Testing has shown that light buffer brush pressure produces the best oil patterns. We recommend starting with a measurement of 'B' and setting the lightest brush pressure that results in an acceptable oil pattern. When oiled, the lane surface should have a uniform sheen. If the pressure between the buffer brush and the lane is too light, the brush will still get oil from the oil transfer roller, but the brush will not be able to apply oil to the lane properly and can leave dry (dull) spots or visible washboard patterns. Dry spots indicate uneven lane surfaces or depressions in the lane surface and may require more brush pressure. When the oil tank wicks are disengaged from the transfer roller, no more oil is transferred *to* the buffer brush, and therefore, the remainder of the lane should receive a diminishing amount of lane dressing. However, if the buffer brush is not properly adjusted against the surface of the lane, the dressing will not have been properly removed from the buffer brush and will continue to be deposited farther down the lane than normal. This will cause insufficient lane dressing to be deposited at the head of the lane and extra lane dressing in the transition area of the lane.

Too much brush pressure can actually have the effect of sweeping *existing* oil down the lane in front of the brush. This can result in too little oil in some places and a "wall" of oil where the brush is lifted from the lane surface. It is important that the correct lengthwise taper of conditioner exists on the lane to help retain the natural "twisting or rotational" energy that the bowler has put into the bowling ball. When sufficient conditioner is deposited, this twisting or rotational energy is retained by the ball while in the head area of the lane and allowed to be released, giving the ball its hook or "drive", when the ball enters the relatively clean and dry back end of the lane.

The pressure adjusting tool consists of a vinyl gauge strip and an aluminum plate that contains a series of bars with an alphabetical scale. These parts are

connected together with a spring and two screws mounted in a slot in the vinyl strip (see Figure 3-1). Prior to taking pressure measurements, carefully inspect the tool for signs of excessive wear or damage. Operate the tool through its full range to ensure freedom of movement. **DO NOT** tighten the nuts that connect the vinyl gauge strip to the aluminum plate, as this will restrict movement. Keep the pressure adjusting tool clean, especially in areas where there is relative movement between parts. Dirty or worn surfaces can increase friction between components, resulting in a reading that is higher than the actual brush pressure. It is normal for the underside of the vinyl strip to be slightly rough.

In order to obtain consistent results, however, it is important that the tool be used properly. Before taking this measurement, the brush must be normally oily. Taking this measurement with a dry brush will result in a bad reading. At least weekly, check the buffer brush's pressure against the lane and adjust as necessary.

To measure the buffer brush pressure, proceed as follows:

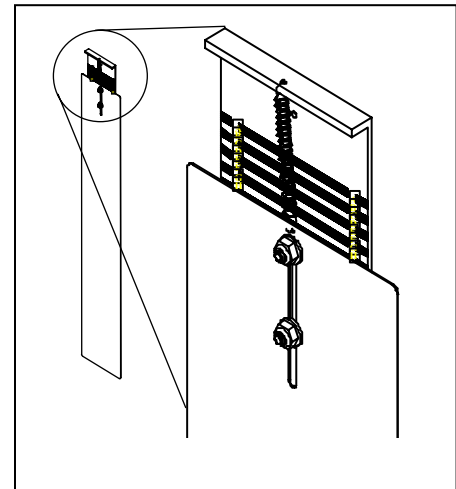

**Figure 3-1,** Pressure Adjusting Tool - RP-43

1. Select Menu Function 94, *Adjust Buffer*, and press the START push button twice. The machine will travel approximately 12 feet down the lane and stop.
2. Press the DOWN ARROW key to start the buffer motor and engage the buffer brush against the lane surface.
3. Grasp the pressure adjusting tool by the aluminum plate with the alphabetical scale facing up. **DO NOT** twist the aluminum plate in relation to the vinyl strip or touch the spring or vinyl strip while taking a pressure measurement.
4. From the rear of the machine, insert the end of the vinyl strip under one end of the rotating brush so that the end of the vinyl strip extends a few inches past the far side of the brush
5. Hold the aluminum plate just off the lane's surface, and slowly pull the tool away from the machine while observing the scale. Pull straight away from the brush without lifting the aluminum plate up away from the lane. The correct reading is one obtained while the tool is in motion, not the indication obtained when the vinyl strip breaks free (first begins to move). The normal pressure range is 'B' to 'C' on the tool's alphabetical scale.

6. Repeat the measurement on the other end of the brush and in the middle of the brush. Brush pressure should be as even as possible across the width of the lane.
7. If an adjustment is necessary, each brush linkage is fitted with a hexagonal linkage adjustment nut (see Figure 3-2) for this purpose.



**CAUTION**

**DO NOT place your hands or fingers inside the solenoid covers. The solenoids operate with considerable force and present a severe pinching hazard.**

- To increase the brush pressure, adjust the linkage adjustment nut in the plus [+] direction, as shown on the sticker near the adjustment nut, to shorten the length of the linkage.
- To decrease brush pressure, lengthen the linkage (move the adjustment nut in the minus [-] direction).
- Limit adjustments to no more than ½ turn (3 flats) of the hex nut (on each side of the machine) at a time. The linkage contains a detent spring to help the nut maintain its setting. This spring also provides tactile feedback each time the nut is adjusted one flat.

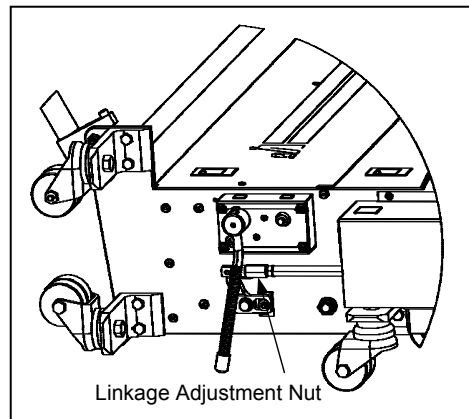

**Figure 3-2, Buffer Brush Pressure Adjustment**

8. After making any necessary adjustments, press the MANUAL REVERSE push button to return the lane machine to the foul line.

## Vacuum System Maintenance

The emulsion of cleaner, oil, and dirt is removed from the lane surface by the vacuum motor and the vacuum head. The vacuum head is wider than the lane and contacts the lane with two urethane squeegees. The squeegees are ribbed to allow formation of the vacuum yet still allow the liquid emulsion to pass under the squeegee. Wipe down the squeegees every 15 to 20 lanes and at the completion of each machine use.

Avoid excessive vacuum head pressure. The vacuum head pressure against the lane should be the minimum pressure and minimum squeegee deflection that will pick up all of the liquid. Judge the vacuum head pressure by the liquid pick-up ability and squeegee deflection – not by how clean the lane is. Squeegee deflection should be even across the lane.

To adjust the vacuum head pressure:

1. Select Menu Function 95, *Adjust Cleaner Pad & Vacuum Head*, and press the START push button twice. The machine will travel approximately 35 feet down the lane at which point the vacuum head squeegee will engage against the lane surface. The machine then travels an additional two feet down the lane to ensure proper deflection of the squeegee on the lane surface.



### WARNING

**Use extreme care when adjusting solenoid linkages. Very hot surfaces and a severe pinching hazard exist under the solenoid covers.**

2. Observe the deflection of the vacuum head squeegee against the lane. The squeegee must be deflected against the lane by the minimum amount required to pick up all of the liquid from the lane. If more or less pressure is needed, simply turn the adjusting nut on the vacuum head solenoid linkage on the applicable side of the machine in the plus (+) or minus (–) direction until the desired deflection and pick up ability are achieved. See Figure 3-3.

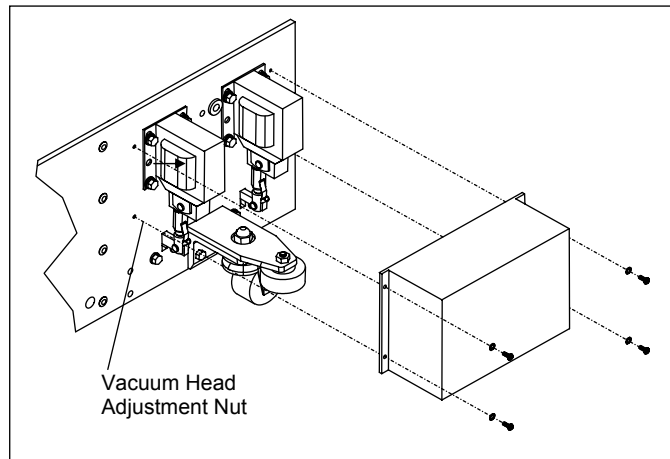
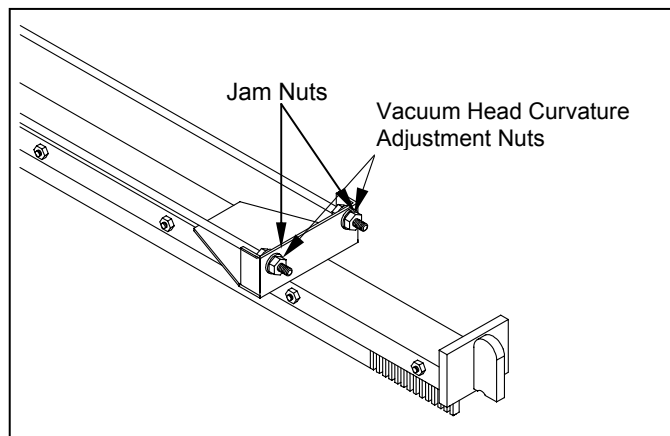

**Figure 3-3,** Vacuum Head Adjustment Linkage

3. The vacuum head has a shape that is adjustable. It is important that the shape of the vacuum head conform to the left-to-right shape of the lane surface when the vacuum head is engaged against the lane. The shape of the vacuum head is factory set and should not require adjustment. However, if the vacuum head does not conform to the left to right shape of the lane surface when the vacuum head is engaged against the lane surface, proceed as follows:

Remember – The vacuum head must be engaged against the lane surface when *checking* this adjustment!

- a) To increase the amount of curvature of the vacuum head, loosen the jam nuts and tighten the adjustment nuts on the ends of the adjusting rods (see Figure 3-4).
- b) To decrease the amount of curvature of the vacuum head, loosen the adjustment nuts on the ends of the adjusting rods.
- c) Tighten the jam nuts to lock in the adjustment.



**Figure 3-4,** Vacuum Head Curvature Adjustment

## S E R V I C E   A N D   R E P A I R

4. After making any necessary adjustments, press the MANUAL REVERSE push button to return the lane machine to the foul line.

Replace the squeegees when they become rounded and shiny from use, approximately every two years.

To replace the squeegees:

1. Disconnect the vacuum hose.
2. Place the machine in the storage position.
3. Remove the vacuum head assembly by moving the retaining springs out of the notches in the end tabs of the vacuum head assembly and then remove the vacuum head from the machine.

### NOTE

**Replace the squeegees one at a time to avoid inadvertently switching the stud bars. THE STUD BARS ARE NOT INTERCHANGEABLE!**

4. Remove the nuts from one of the squeegees using a 5/16-inch wrench.
5. Replace the existing squeegee on the stud bar with a new one, and reinstall the stud bar using the nuts removed earlier. Do not over tighten the nuts. The smooth side of the squeegee must be against the stud bar.
6. Repeat Steps 4 and 5 for the remaining squeegee.
7. Adjust the squeegees using a flat surface so that they extend evenly below the vacuum head weldment.
8. Reinstall the vacuum head assembly in the machine, and connect the vacuum hose.
9. Adjust the vacuum head deflection as necessary.

When the squeegees have been replaced properly, the rear squeegee should deflect slightly towards the rear of the machine.

The vacuum motor gasket should be smooth and flat. Replace the gasket if it is wrinkled or buckled, or if it has begun to pull away from the vacuum motor.

To replace the gasket:

1. Carefully pull the gasket off the vacuum motor.
2. Clean the gasket location on the vacuum motor using a scraper to remove most of the material followed by a solvent to remove the remaining residue.
3. Remove the protective backing from the new gasket, and press it firmly in place around the vacuum inlet. Ensure that the gasket does not interfere with the installation and removal of the waste tank.

## **Cleaner Flow System Maintenance**

Use the filter funnel supplied with the HVO SUMMIT S Series when pouring cleaning solution into the cleaner tank. When the lane conditioning program calls for the lanes to be stripped, a relay activates a Fluid Pump. The cleaning solution flows from the tank, through a filter, through the pump to a tee which flows to either a manual flow control valve, or into the spray nozzles. The manual control valve bypasses cleaner back to the cleaner tank. The higher the setting, (more open) the greater amount of bypassed cleaner will flow back to the cleaner tank. This will result in less cleaner to the nozzles. Adjust this valve to obtain the desired spray rate.

For long life and proper operation, the cleaner system filter should be cleaned monthly. To clean the filter:

1. Disconnect the tubing that leads from the cleaner tank to the filter assembly at the cleaner tank. The tank is equipped with a quick disconnect for this purpose.
2. Unscrew the filter bowl from the filter housing, and remove the screen. The filter housing can be swung out away from the fire wall to make this easier. You should be prepared for a little cleaner spillage from the filter.
3. Clean the screen by placing it under running water.
4. When clean, reassemble the filter assembly and plug the quick disconnect into the tank fitting.

A relay controls the fluid pump that controls the cleaning solution flow. The pump is either ON or OFF. This pump, however, is capable of controlling and varying cleaning solution flow by turning the pump on or off within a two second window. The pump remains open for a controlled percentage of time during one relay/pump operating period. For example, the valve's operating period is two seconds and the control setting is for 100% flow, the pump will



remain on 100% of the time. If **50%** flow is called for, the pump remains ON for 50% of every cycle period or 1 second and OFF for 50% of every cycle period or 1 second. A **75%** flow signal causes the pump to remain on for 1.5 second and then off for .5 seconds. This cycle is repeated for as long as cleaning solution is called for. The result is the ability to adjust cleaner flow, as needed, to ensure correct stripping at any machine speed. With the spray cleaning it is recommended to use 100% flow in the “IN OIL” area with the manual valve adjusted for proper flow. Additionally, the factory settings for the “OUT of OIL” flow are also set at 100%. You may adjust the percentage less than 100% in the “OUT of OIL” area if applying too much cleaner, by reducing the percentage of flow. In order to see a considerable change in the flow of cleaner, you must make a significant change in the percentage settings.

### **To adjust the cleaner pad pressure:**

1. Select Menu Function 95, Adjust Cleaner Pad & Vacuum Head, and press the START push button twice. The machine will travel approximately 35 feet down the lane at which point the cleaner pad will engage against the lane surface. The machine then travels an additional two feet down the lane to ensure proper contact between the pad and the lane surface. The vacuum head adjustment should have already been made, and the vacuum head must be against the lane with the vacuum head squeegee deflected.
2. The cleaner pad is designed to wet the lane and agitate the oil. To ensure this, a pressure reading of “B” to “C” on the RP-43 pressure adjusting tool supplied with the HVO SUMMIT S Series is required (see Pages 3-4 through 3-6 for more information on the use of the pressure adjusting tool). Check the pad pressure on the outsides and in the middle of the pad. The cleaner pad pressure should be checked while the cleaner pad is normally wet. An excessively wet pad should be wiped free of excess cleaner before it is adjusted against the lane.



#### **WARNING**

**Use extreme care when adjusting solenoid linkages. Very hot surfaces and a severe pinching hazard exist under the solenoid covers.**

3. Pressure is adjusted by simply turning the adjusting nut on the linkage at the solenoid until the correct pressure reading is obtained. To increase the brush pressure, adjust the pressure adjusting nut in the plus (+) direction to shorten the length of the linkage. To decrease brush pressure, rotate the nut in the minus (–) direction to lengthen the linkage. A detent spring that is part of the linkage maintains the setting (see Figure 3-5).

4. After making any necessary adjustments, press the MANUAL REVERSE push button to return the lane machine to the foul line.

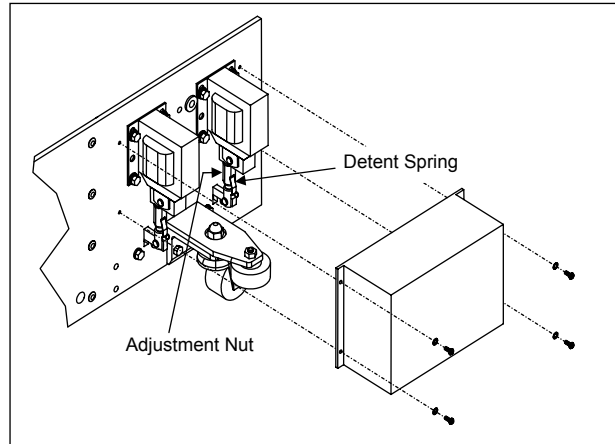
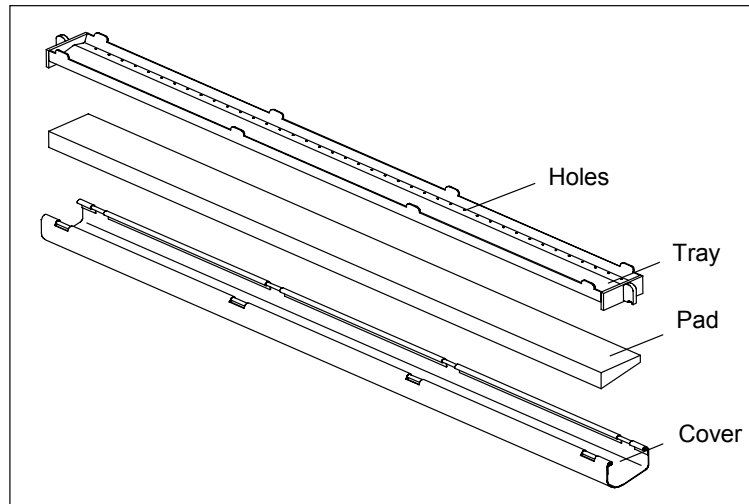

**Figure 3-5,** Cleaner Pad Adjustment Linkage

## Cleaner Pad Maintenance

It is important that the cleaner pad assembly be properly maintained and replaced when necessary. At least every four months or whenever the wear pattern is wavy and irregular, replace both the cleaner pad cover and foam pad or sponge. The cover is attached to the cleaner pad tray by two rods that fit into hems sewn along the edges of the cover. These rods hook over tabs built into the cleaner tray to secure the cover in place. The foam pad is tapered. The thinner edge of the sponge should go directly under the section of the cleaner pad tray with the most holes in it. The thicker end of the foam pad should go under the part of the cleaner pad tray with the least number of holes (see Figure 3-6). The cover should surround the metal tray and foam pad. The shape of the finished assembly should be smooth and consistent with no lumps or tight or loose spots.

The wet cleaner tray as well as the drip tray should be wiped off whenever lint or dust buildup is excessive and whenever cleaner is added to the cleaner tank. Also, wipe them down at the completion of each machine use.



**Figure 3-6, Cleaner Pad Assembly**

Whenever the lane machine is not in use, store the cleaning pad assembly in the storage container supplied with the HVO SUMMIT S Series. The storage container should contain the same cleaning solution, at the same dilution strength, that is being used to strip the lanes. Wipe any lint or dirt from the cleaning pad before immersing the assembly in the storage container. Add cleaning solution as needed to ensure that the cleaner pad's foam pad is completely submerged during storage. Replace the cleaning solution in the storage container whenever it becomes dirty, but at least every two months.

## Waste System Maintenance

Clean the inside of the waste tank at regular intervals, but at least weekly.

To clean the tank:

1. Place the machine in the operating position.
2. Open the main compartment's hood and disconnect the vacuum hose from the waste tank's inlet nozzle.
3. Slide the waste tank locking latches to the side to unlock the tank, and remove and empty the waste tank.
4. Insert a water hose into the tank's inlet nozzle protruding from the side of the waste tank and flush the tank with water. Agitate the tank vigorously.
5. When the tank is clean, empty the tank, reinstall it in the machine, and lock it in place.
6. Reconnect the vacuum hose.

## Periodic Lubrication

The bearings in motors and drive system components are pre-lubricated and sealed and do not need further lubrication. Certain other components, however, do need periodic lubrication to ensure continued optimal performance. Lubricate the following components at the prescribed intervals. Some items may require lubrication more frequently depending on the number of lanes in your center and the frequency that they are maintained. Perform this maintenance away from the lanes to prevent getting oil or grease onto the lane or the approach. **DO NOT USE ANY LUBRICANTS CONTAINING SILICONE.** If silicone gets on the lane surface, buffer brush, or cleaner pad, it will interfere with the normal deposition of conditioner.

## Drive Chain and Sprockets



### WARNING

**DO NOT leave the machine unattended with the Maintenance interlock key installed.**

Approximately every three months, lubricate the drive chain and sprockets with a good quality wheel bearing grease. The easiest way to apply it is to use a small stiff-bristled brush (such as an acid brush). Place the HVO SUMMIT S Series on 4 x 4 blocks to lift the drive wheels off the ground and then insert the spare interlock key in the interlock switch mounted on the center of the firewall in the main compartment. Use menu function 91 (Test Function) to operate the drive motor. Apply grease while the motor is in operation. Remove any excess. After lubricating, remove the interlock key.

## Transfer Roller Drive Chains and Sprockets

Approximately every three months, lubricate the transfer roller drive chains and sprockets lightly using a good quality 80 to 90 weight gear oil (do not use grease). Remove any excess. Before lubricating the chains, it is necessary to remove the guard on each end of the transfer roller. The guards are secured to the transfer roller drive shaft support arms. Remove the guards by removing the screw that secures both the guard and the roller spring. Use menu function 91 (Test Function) to operate the transfer roller motor. After lubricating the chains, reinstall the springs and guards.

### Buffer Drive and Idler Assemblies

Approximately every three months, lubricate the buffer drive and idler assemblies, as specified below, using a good quality wheel bearing grease.

To apply grease, proceed as follows:

1. Place the machine in the storage position and remove the buffer brush. Store the brush carefully so that the bristles are not damaged or deformed.
2. Place a thin bead of grease approximately ¼-inch wide along the inside face of the side panel just below the idler assembly as shown in Figure 3-7.

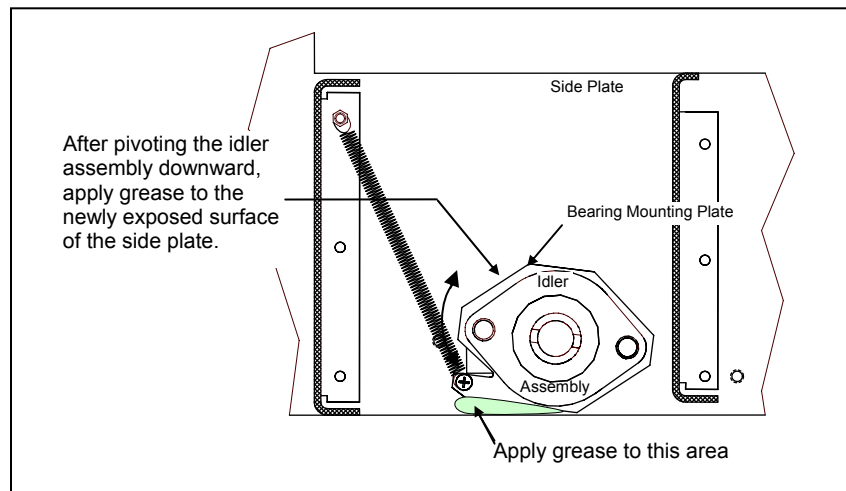

**Figure 3-7**, Lubricating the Buffer Idler Assembly

3. Operate the idler assembly's solenoid linkage by hand so that the idler assembly lowers to its full down position.
4. With the idler assembly in the full down position, place a thin bead of grease approximately ¼-inch wide along the newly-exposed surface of the side panel just above the idler assembly as shown in Figure 3-7.
5. Operate the idler assembly's solenoid linkage by hand 8 to 10 times to help work the grease between the side plate and the idler's bearing mounting plate. Wipe away any excess grease that is not in the idler assembly's path of travel.
6. Repeat Steps 1 through 5 for the buffer drive assembly.
7. When complete, lightly lubricate the spring-loaded idler end of the buffer brush with grease, and reinstall it in the machine.

## **Vacuum Head and Cleaner Pad Slide Block Mounts**

Approximately every three months, apply a good quality lithium grease in the slots of the vacuum head and cleaner pad slide block mount assemblies as follows. Do not overlubricate.

1. Place the machine in the upright (storage) position.
2. Remove the vacuum head and cleaner pad (if installed) from the machine.
3. Apply grease to the walls of the slots of the slide block assemblies below the pivot arms using a small brush.
4. Reinstall the vacuum head and cleaner pad, as applicable.

The cleaner pad slide blocks may need to be lubricated more frequently because the cleaner pad is stored submerged in cleaning solution when not in use. This causes the grease to be depleted more rapidly.

## **Electrical Repairs**

### **Control Module**

The HVO SUMMIT S Series is controlled by a programmable control module and speed control box. The control module and speed control box are easily replaced. In case of failure, a replacement module can be easily installed, and the original module sent to the factory or authorized service center for repair. See Figure 3-8.

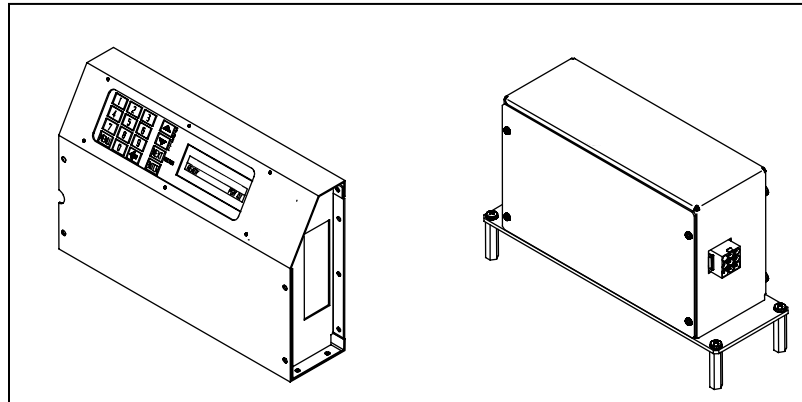

**Figure 3-8,** HVO SUMMIT S Series Control Module and Speed Control Box

The HVO SUMMIT S Series lane machine utilizes three circuit boards in the main controller and two more in the speed control box. Do **NOT** attempt to repair any of these circuit boards. The only circuit board that should be removed by the user is the relay board. For repairs to all other boards, send the entire box (either the control module or the speed control box) to QubicaAMF Bowling Products, Inc. for repair. Repairs will be performed on an "in-warranty" or "out-of-warranty" basis. In certain cases it is possible that the circuit board will be beyond repair and the circuit board and/or control box will have to be replaced.

To remove the relay board, perform the following:

1. If there is any question as to which board needs to be removed or how to remove it, contact customer service at 1-800-342-5263 or 804-730-4300.
2. Unplug the power cord from the machine.
3. Unplug the 20-pin connectors from the control module.
4. Remove the four screws that mount the control module to the dash, and unplug the remaining electrical connectors from the control module.
5. Remove the back cover from the control module. The relay board is the circuit board that is attached to the back cover.
6. Disconnect any connectors or cables connected to the relay board. If necessary, label them to help in reinstallation.
7. Unscrew the fasteners holding the circuit board to the panel.
8. If returning the circuit board, complete a Product Trouble Report describing the problem, include the name of your bowling center and the return address, and obtain a return authorization (RA) number.
9. Package the circuit board to prevent damage, and return as directed.

10. Install the new circuit board and control module by reversing the sequence of Steps 1 through 7.

## **Speed Control Box**

Should the speed control box ever need servicing, remove as follows:

1. Unplug the HVO SUMMIT S Series, power cord.
2. Unplug the 9-pin connector from the side of the speed control box.
3. Remove the four screws that secure the speed control box to the mounting posts (standoffs) leaving the standoffs attached to the bottom plate.

Before returning the unit to QubicaAMF Bowling Products, Inc. for repair or replacement, complete a Product Trouble Report and obtain a return authorization (RA) number.

## **Reversing Trip Arm Switch**

The reversing trip arm microswitch must be adjusted to allow the HVO SUMMIT S Series to start without immediately reversing. The machine can immediately reverse after starting if the trip arm is set too sensitively. If the microswitch needs to be adjusted, it is adjusted as follows: (See Figure 3-9.)

1. Place the machine on the lane just beyond the foul line.
2. To check for proper adjustment, lift the front of the machine with the front handle approximately 5/16 to 3/8 of an inch. The microswitch should not actuate (you should be able to hear it click if it does). You can also use Menu Function 91, *Test Function*, to observe the switch's position (OFF is normal, ON is actuated). If this adjustment is not correct, or the machine reverses after a 2 second delay when the start button is pushed, the microswitch's leaf arm needs to be adjusted.
3. To adjust the microswitch's leaf arm, block the front of the machine up so that the reversing trip arm wheel does not contact the lane. Hold the leaf arm against the microswitch at the center of the leaf arm so that the tail of the leaf arm can be bent. Bend the tail of the leaf arm up or down slightly as needed. Recheck and adjust until you achieve the desired result.



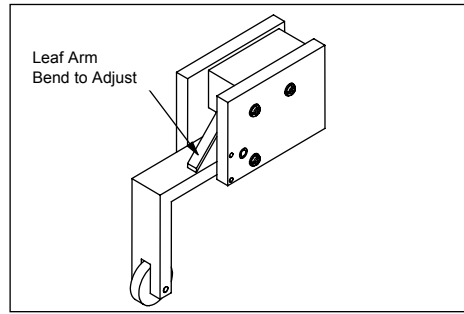

Figure 3-9, Reversing Trip Arm Assembly

### Fuse Block Assembly

The HVO SSUMMIT S Series is equipped with a fuse block assembly that is conveniently located within the main compartment. Should you ever need to change a fuse, first try to determine what caused the fuse to blow. Faulty parts, such as a sticky solenoid or solenoid linkage, worn bushings or bearings, as well as bad electrical components can result in blown fuses. Whenever possible, correct the cause of the problem before replacing the fuse. If the fuse blows again following replacement, the faulty component(s) may need to be replaced.

To replace a fuse, determine the correct fuse location on the fuse block by identifying the affected component's wire color and wire number and then locate the same wire where it attaches to the load side of the fuse block. The load side of the fuse block is labeled with a series of even numbers. On the fuse block, pivot the top section of the individual fuse holder upward as shown below. This allows access to the cover on the side of the fuse holder.



Figure 3-10a, Pivoting Fuse Holder



Figure 3-10b, Fuse Replacement

Opening the fuse access cover disengages the fuse from the holder. **Replace the fuse with a 5 x 20 mm fuse of the same current and voltage rating only!** This rating is engraved on the end of the fuse and is indicated on the

label on the fuse holder’s access cover. Place the new fuse inside the cover and snap the cover into place. The fuse will automatically be seated in the holder. **Do not force the cover shut!** It should take very little effort if the fuse is placed in the holder correctly. A spare fuse can be stored in the upper part of the fuse holder.

**Power Cord**

A 125-foot long power cord (mains lead) is supplied with your lane machine.

**Note for 220 / 240 Volt Machines: Prior to use, the appropriate 230V three-prong plug will need to be installed on the power cord by a qualified electrician in accordance with local electrical codes.**

Do not use any other power cords either singly or in combination with the one provided. The three wires in this mains lead are colored in accordance with the following code:

220 / 240 Volt		110 / 120 Volt	
Green & Yellow	– Earth	Green & Yellow	– Earth
Blue	– Neutral	White	– Neutral
Brown	– Live	Black	– Live

1. Inspect the power cord before and after performing lane maintenance. If the power cord’s sheathing has pulled away from the plug, becomes frayed, cut, or shows excessive wear, have the power cord properly repaired by a qualified person or replace it with the power cord specified for this machine as shown in Appendix A of this manual.

During lane maintenance, the operator feeds the power cord into the channel between lanes as the machine travels toward the pin deck and retrieves the power cord as the machine returns to the foul line. This is done to keep the power cord off the lane surface, which could ruin the oil pattern being applied to the lane, and more importantly, to keep the machine from running over the power cord. Every effort should be made to prevent the machine from running over the power cord!



**WARNING**

**An electrical shock hazard can exist any time the lane machine runs over the power cord.**

2. If the lane machine inadvertently runs over the power cord, carefully inspect the power cord for damage. DO NOT use a damaged power cord.



3. **Should the power cord become entangled in the lane machine, unplug the power cord from the bowling center's electrical receptacle before attempting to clear the power cord from the machine.**

## Peak Performance

In order for the lane machine to perform at its optimum level, the oil tanks must be adjusted so that the wicks exert the correct amount of pressure against the transfer roller. Use the minimum amount of wick pressure against the transfer roller that provides the desired results. Generally, the more pressure exerted against the transfer roller the more oil that is transferred from the wicks to the buffer brush. The term “generally” is used because if too much pressure is applied, the wick becomes pinched between the roller and the tank, and oil transfer is actually reduced.

To ensure proper performance, proceed as follows:

1. Place the machine in the operating position at the foul line.
2. Ensure that electrical power to the machine is disconnected.
3. Verify that the tank solenoids are directly in line with the tank connection tabs so that a straight-line pull is exerted when the solenoids are energized, and verify that the linkage clearances are correct (see Figure 3-11.) There should be a  $\frac{1}{16}$ -inch gap between the shoulder of the linkage pull rod and the tank connection tab when the solenoid is engaged. Adjust if necessary.

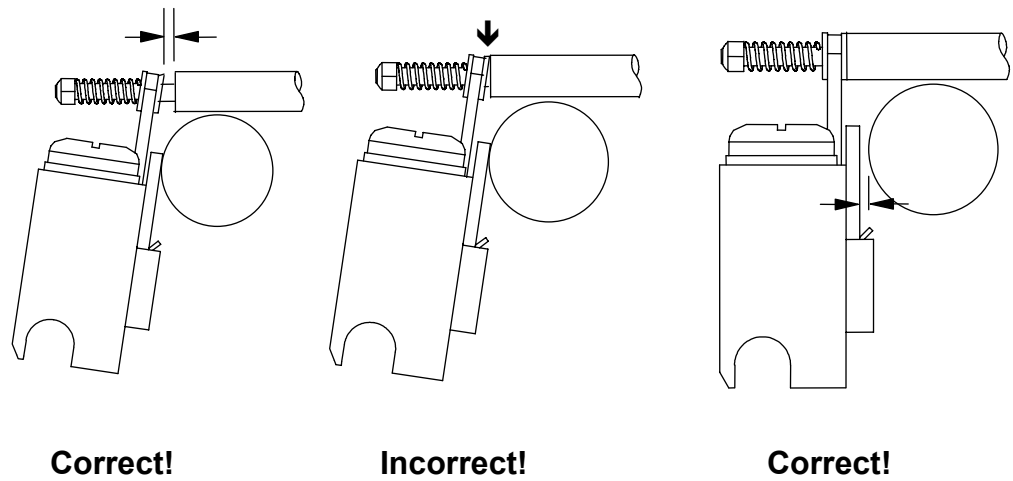

**Figure 3-11, Oil Tank Linkage Adjustment**

4. When beginning lane maintenance, fill the oil tanks using the oil fill bottle so that all the tanks have the same level of oil in them.
5. Plug the lane machine into an appropriately rated electrical outlet.
6. Select Menu Function 92, and saturate the buffer brush for a few seconds.
7. Retrieve the lane conditioning program to be used to condition the lanes, and run that program on the first lane three times. This will ensure that the oil profile is consistent from lane to lane from the very first lane.

Periodically inspect the oil tank linkages and solenoids, and adjust or replace parts as necessary. Changing components, such as springs, spacers, wicks, and washers, with parts not supplied by QubicaAMF Bowling Products, Inc. can adversely affect the machine's ability to achieve satisfactory results.

## Clearing Clogged Nozzles

The nozzles are designed to be clog free and the in-line filter should keep out particles that could clog the nozzles, but a clog may still occur. To clear a clogged spray head, follow the steps below. Perform these steps with the machine in either the **operating** or the **storage** position.

1. Turn the spray head 1/4 turn to the **left** to release it from the connector. The spray head, nozzle, and washer will be released.
2. Soak the spray head in warm water for several minutes then blow air through it from the tip end.
3. Reassemble the washer, nozzle, and spray head.
4. Position the assembled parts against the connector and turn the spray head 1/4 turn to the **right** to secure them in place.

S E R V I C E   A N D   R E P A I R

This page intentionally left blank.

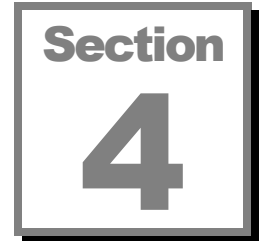

## Troubleshooting

***Problem 1*** - The HVO SUMMIT S Series moves down the lane properly but continues to operate identically all the way down the lane. During the oiling mode, the oil solenoids and buffer brush do not disengage when they should. During the stripping mode, the cleaner pad does not pick up away from the lane until the machine reverses direction at the tail plank.

- A. The distance the machine travels down the lane is sensed by the counter wheel, which rides against the lane surface. If this wheel cannot turn freely, either because of a bind in the movement of the wheel or because it is slipping on excess lane dressing, the machine will not determine distance properly. The result is that the machine will not perform specific functions at all, or they occur further down the lane than expected. To remedy the problem, the counter wheel must be able to rotate freely either by fixing the cause of the binding, or by cleaning the excess lane dressing, dirt, or lint from the wheel, the lane, or both.
- B. The counter wheel or the base plate opening through which it protrudes is dirty. This will prevent the machine from counting or sensing distance properly. If this happens, the machine will not change functions when programmed to do so, or will not change functions at all. Wipe the wheel with a clean cloth. Clear the counter wheel opening of any foreign material.
- C. The wiring from the encoder to the control module has come loose, broken, or the insulation has been damaged. Check this and repair or replace the wiring as necessary. If soldering is necessary, use a low wattage soldering pencil.
- D. The voltage to the machine, *when the machine is being used*, is too low causing an excessive current draw. This can be due to an improperly rated electrical outlet or to excessive pressure against the lane surface by any of the HVO SUMMIT S Series components. Change outlets to one that is

## TROUBLESHOOTING

properly rated, and check the pressure against the lane from the vacuum head, cleaner pad, and buffer brush. Do not use any other power cords in place of or in addition to the one provided.

- E. The encoder has failed. Replace the encoder. If soldering is necessary, use a low wattage soldering pencil.

**Problem 2** - HVO SUMMIT S Series buzzes loudly and may even start slowly when the start button is depressed.

- A. The HVO SUMMIT S Series is really two lane machines in one. Therefore, during the simultaneous oiling and stripping mode, two machines are operating at once. The electrical current associated with this is high by necessity. The HVO SUMMIT S Series needs to be operated on a dedicated, grounded circuit with the appropriate voltage and current rating. Depending on the location of the outlet in relation to the main electrical power panel, the machine may or may not operate properly. If necessary, change the outlet being used, provided it is rated properly, to one that is closer to the incoming electrical supply. Be sure that only the manufacturer-supplied power cord is used.



### WARNING

**Use extreme care when servicing a solenoid. Very hot surfaces and a severe pinching hazard exist under the solenoid covers.**

- B. The solenoids that operate the various components such as the oil tanks, buffer brush, vacuum head, and cleaner pad must be fully engaged when energized. If not, they can emit a loud buzzing sound and can become very hot. If a solenoid is buzzing, check its alignment with the component to which it is attached. The solenoid needs to be exerting a straight-line pull. If it is not, it may not engage fully. If this is the case, align the solenoid. Most of them are equipped with adjustment screws for this purpose. Also, oil or cleaning solution can get on the solenoid's shaft and leave a residue that can prevent proper operation. If cleaning and aligning the solenoid does not remedy the problem, then the solenoid may need to be replaced.

**Problem 3** -Machine runs into the pit.

- A. The reversing trip arm switch is binding. The trip arm exerts downward pressure by its own weight. It is possible that the reversing trip arm is



## T R O U B L E S H O O T I N G

bound in the up position and is not free to move down when the machine reaches the tail plank. Repair or replace the trip arm assembly as necessary.

- B. The reversing trip arm microswitch is not working properly. Replace the microswitch.
- C. A relay is sticking on the control module high voltage relay board. Replace the control module, and send the original control module back to QubicaAMF Bowling Products, Inc. for repair.
- D. Braking delay is too long. Select Menu Function 82, *Reversing Switch Brake Delay*, and enter a braking delay time that results in the proper operation of the machine.
- E. The machine fails to shift to slow speed as it approaches the end of the lane causing its momentum to carry it into the pit. Either the counter wheel is sliding and not rotating freely or the speed control box needs repair or replacement. Repair or replace the defective component.

**Problem 4** - The buffer brush and/or oil solenoids do not engage during the reverse run when this option is selected.

- A. Low receptacle voltage and/or current. The circuit should be rated at 220 to 240 volts with 20 amps and 110 to 120 volts with 30 amps respectively.
- B. Faulty ground (earthing) connection. Check the machine's power cord ends, receptacle wiring, and main electrical power wiring to insure that the circuit is properly grounded.

**Problem 5** - Oil solenoids or buffer brush stays on at the turnaround point in the Short Run mode.

- A. Low receptacle voltage and/or current. For best operation, the circuit should be rated at 220 to 240 volts and 20 amps, or 110 to 120 volts and 30 amps respectively.
- B. Faulty ground wire. Check the machine's power cord ends, receptacle wiring, and main electrical power wiring to insure that circuit is properly grounded.

## T R O U B L E S H O O T I N G

**Problem 6** - Machine does not reverse at the Short Run distance selected.

- A. Low receptacle voltage and/or current. For best operation, the circuit should be rated at 220 to 240 volts and 20 amps, or 110 to 120 volts and 30 amps respectively.
- B. Faulty ground wire. Check the machine's power cord ends, receptacle wiring, and main electrical power wiring to insure that the circuit is properly grounded.
- C. The counter wheel/encoder is not functioning properly. Check the wire connections to the plug for this sensor. Make sure the wheel rotates freely and is in contact with the lane surface. Check the electrical connections at the encoder and at the connector plug.

**Problem 7** - Vacuum head or cleaner pad momentarily engages against the lane surface on the return movement of the machine, usually coinciding with the start of the buffer motor.

- A. This is usually a sign of low voltage either within the bowling center or on the electrical line or receptacle being used to power the machine. Inspect for this and correct as necessary.
- B. Changing electrical circuits to a different receptacle on a different line can sometimes solve this problem.

**Problem 8** - Cleaner flow is erratic or low. HVO SUMIT S Series.

- A. Check the Cleaner Pump for proper operation.
- B. Verify that the bypass flow control valve is set properly.
- C. Verify the Cleaner Pump Relay is turning the pump on and the connection to the relay is good. If not, replace the relay.
- D. The cleaning solution filter may be plugging. Clean the filter in accordance with the *Cleaner Flow System Maintenance* subsection (see Page 3-10).

## T R O U B L E S H O O T I N G

- E. Check for kinks or crimps in the cleaner tubing between the tank and the nozzles. Plastic wire ties supporting the tubing can be too tight and pinch off flow.
- F. Check nozzles for clogging. Clean the nozzles in accordance with the *Clearing Clogged Nozzles* subsection (see Page 3-22).
- G. Check “IN OIL” and “OUT of OIL” settings for cleaner flow. If less than 100%, the pump will cycle on and off causing spray to turn ON and OFF. This is normal.

**Problem 9** - Machine operation is jerky during speed changes.

- A. Check for binding of drive system components. Accumulations of dirt and residue or anything wrapped around the drive shaft, especially near the drive wheels, can adversely affect the performance of the machine.
- B. Drive chain is binding or has a kink in it. Ensure that the chain is lightly greased and that each link moves freely in relation to adjacent links.
- C. The drive chain’s master link has been assembled incorrectly. The prongs of the master link should be inserted into the chain from the waste tank side of the chain. If not, they will contact the shoulder of the drive shaft sprocket causing a jerky motion.

**Problem 10** - Actual *travel* speed is slower than the programmed *travel* speed.

- A. If the software determines that the machine will not attain full *travel* speed before the machine is due to shift to the programmed *conditioning* speed (because of a very short distance to be traveled), the machine is designed to shift directly to the programmed *conditioning* speed instead of the programmed *travel* speed. This is normal and prevents short-cycling the drive motor.
- B. Try programming a slower *travel* speed. The machine may be able to attain this speed in the amount of time available, and since even the slowest *travel* speed is faster than the fastest *conditioning* speed, a time savings might be realized.
- C. The machine speed factor needs adjustment. Have the lane machine calculate a speed factor using Menu Function 83. For specific information on using menu functions, refer to the *HVO Summit S Series Programming Guide*, 294-005-022.

# TROUBLESHOOTING

This page intentionally left blank.

# DRAWINGS AND PART NUMBERS

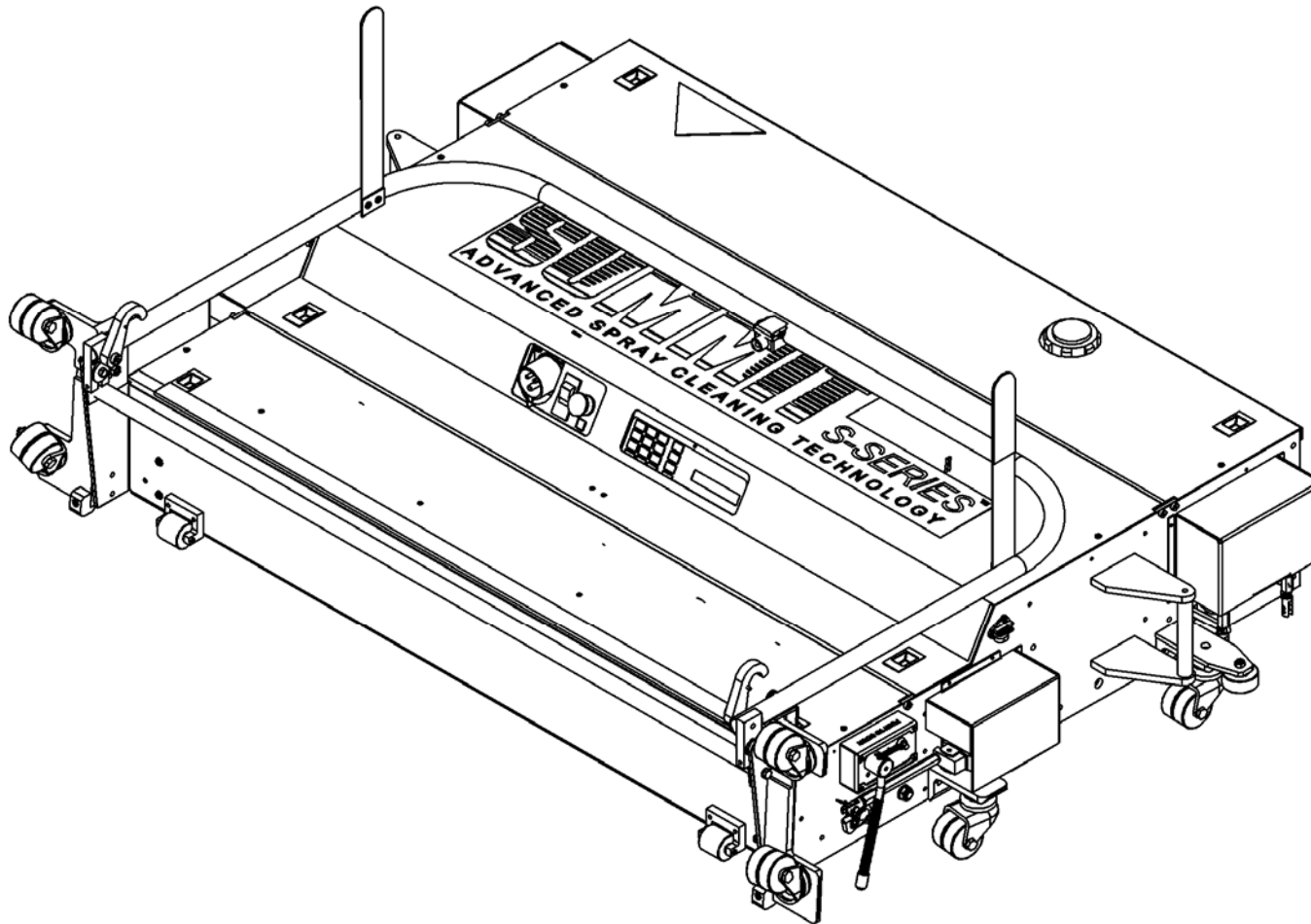

**294-002-413**  
**OIL HOOD ASSEMBLY**

	<b>PART NO.</b>	<b>DESCRIPTION</b>	<b>QTY</b>
1	04-323	SLIDE LATCH, FLUSH	2

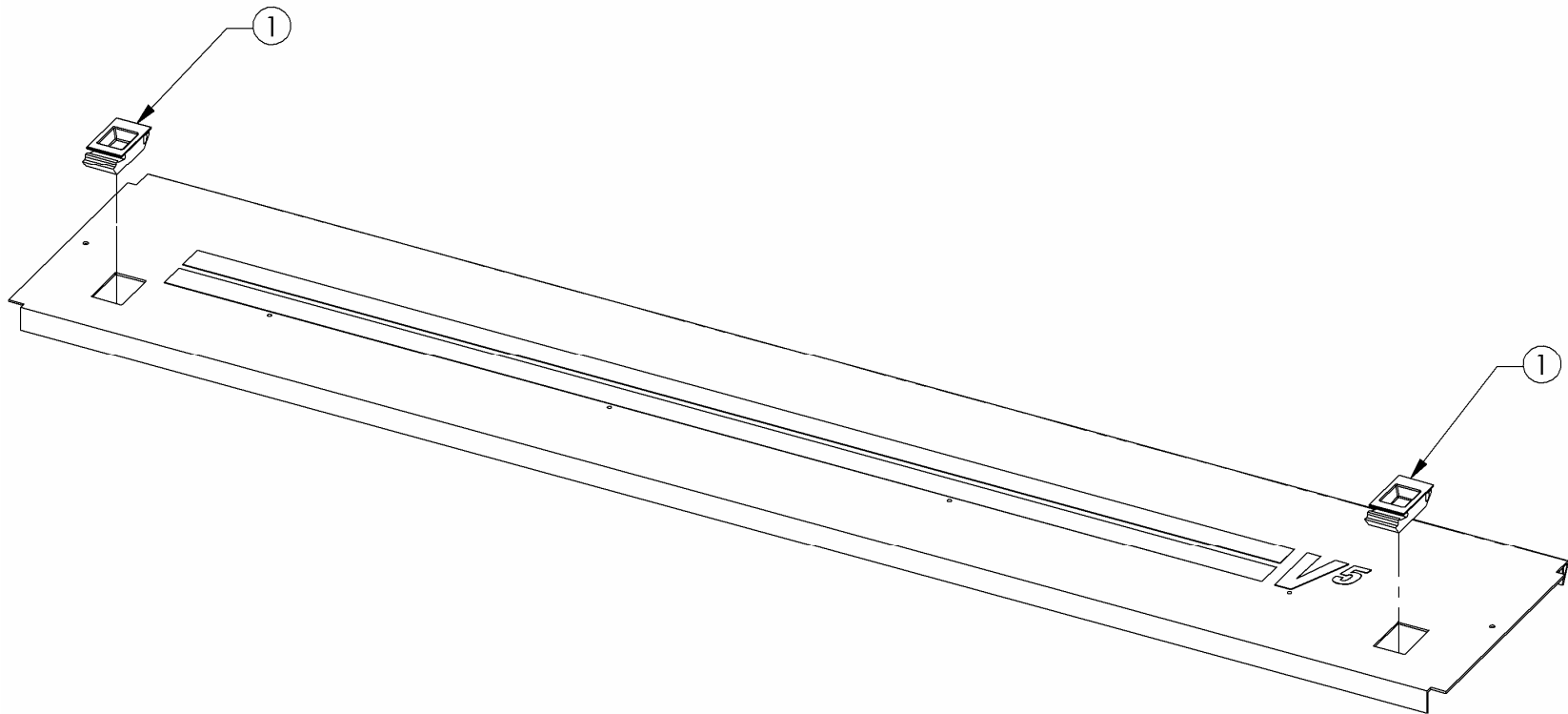

**294-002-423**  
**ELECTRICAL HOOD ASSEMBLY**

	<b>PART NO.</b>	<b>DESCRIPTION</b>	<b>QTY</b>
1	294-002-467	ELECTRICAL HOOD	1
2	04-323	SLIDE LATCH, FLUSH	2
3	294-002-060	HINGE BAR	1
4	01-130	RIVET, 1/8 X 1/2 LONG, ALUMINUM	5

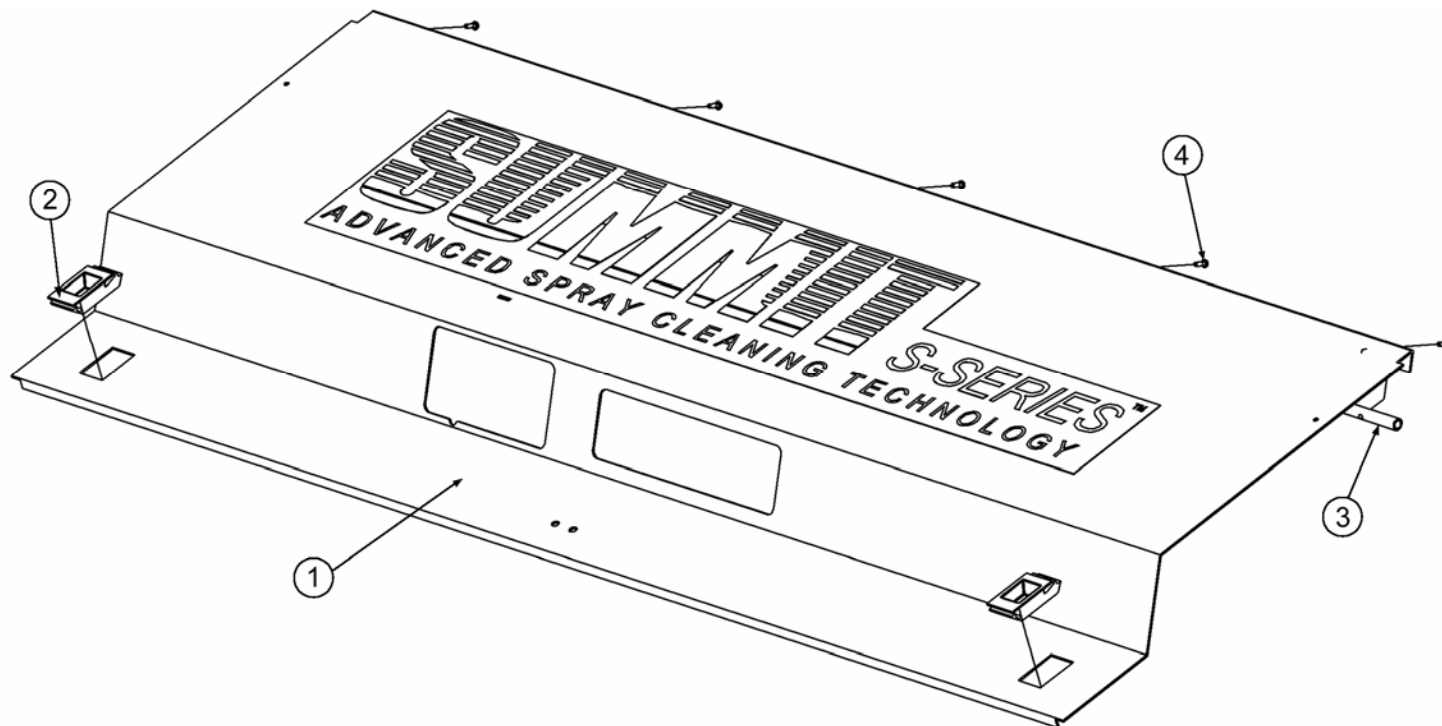

**294-002-414  
CLEANER HOOD ASSEMBLY**

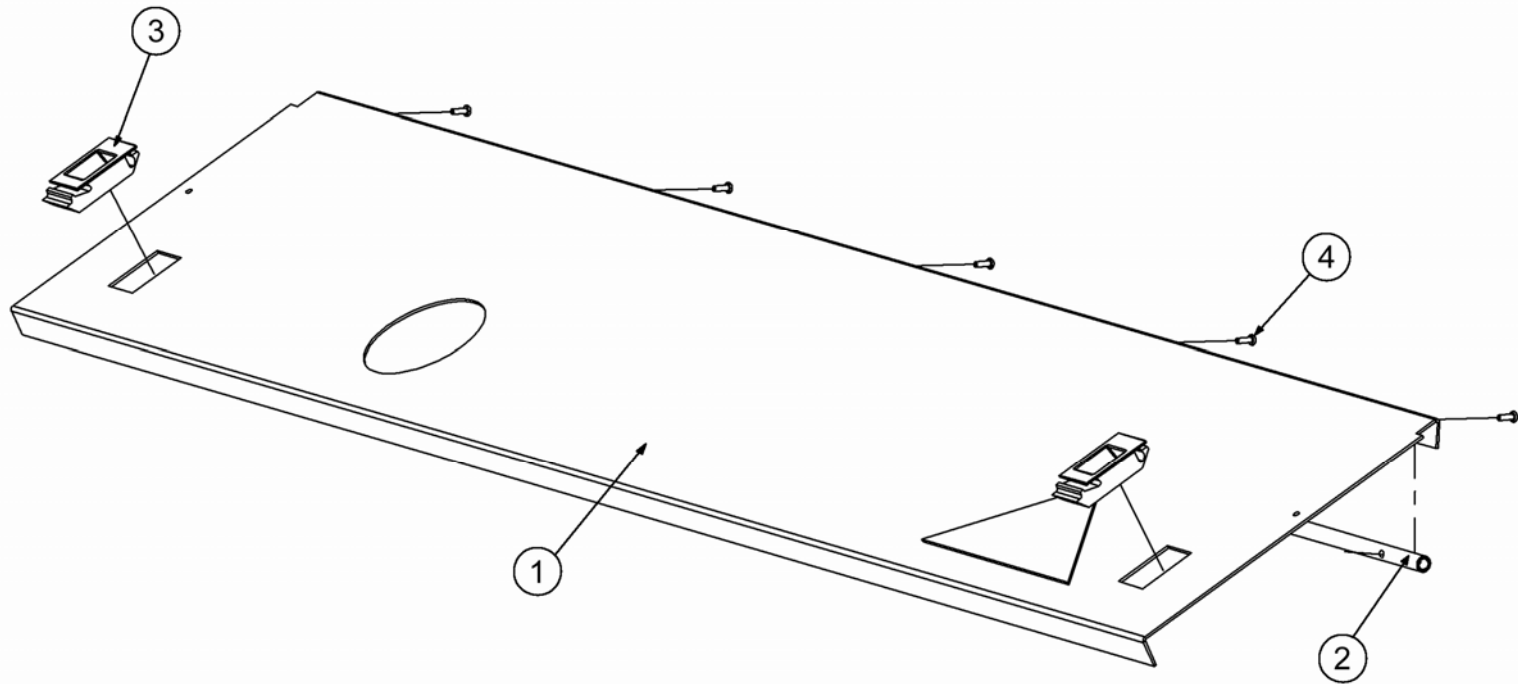



**294-002-414****CLEANER HOOD ASSEMBLY**

	<b>PART NO.</b>	<b>DESCRIPTION</b>	<b>QTY</b>
1	294-002-437	CLEANER HOOD	1
2	294-002-060	HINGE BAR	1
3	04-323	SIDE LATCH FLUSH	2
4	01-130	RIVET, 1/8 X 1/2 LONG, ALUMINUM	5

**BODY ASSEMBLY  
FRAME ASSEMBLY, OIL TANK ASSEMBLY**

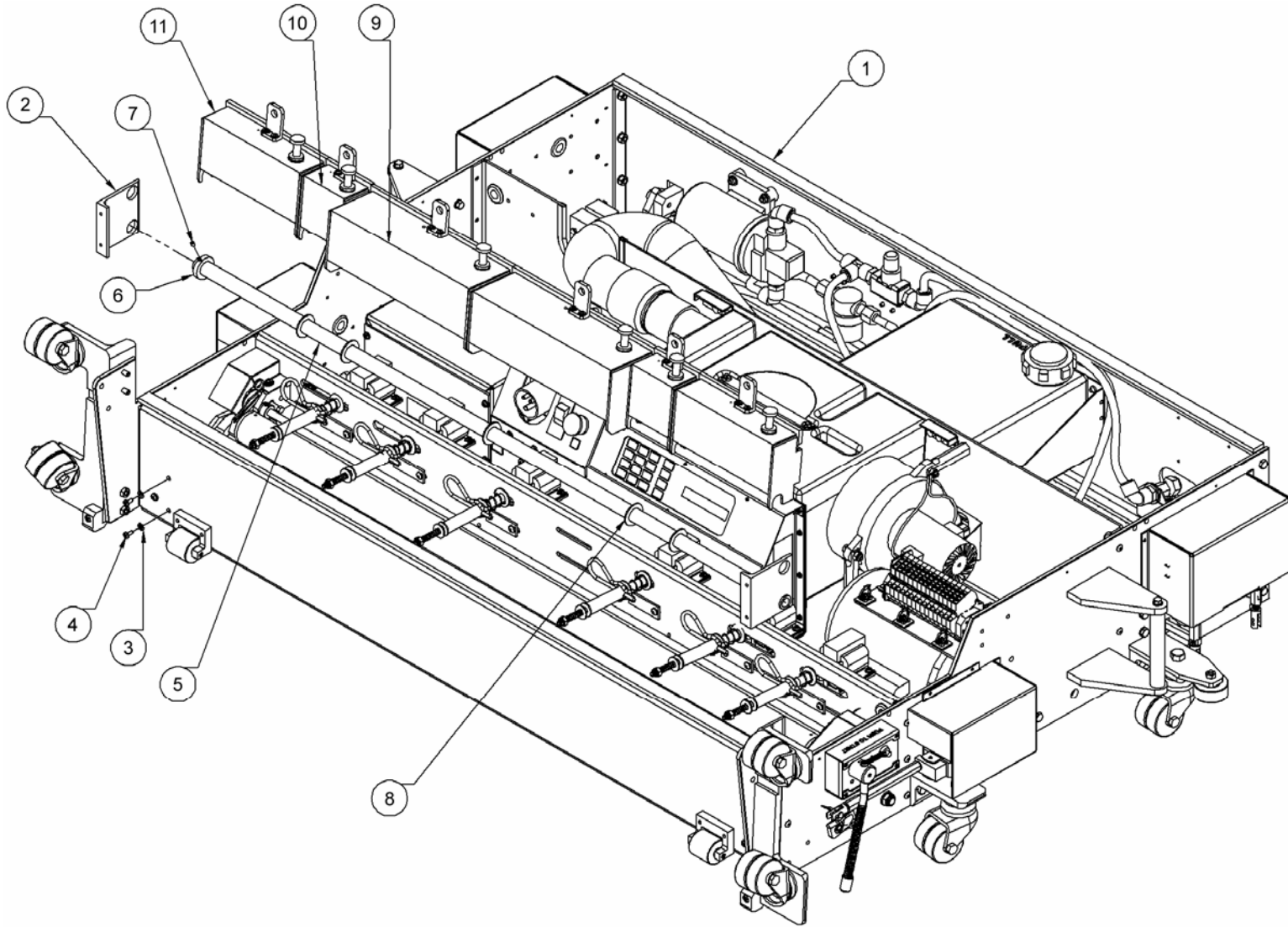

**BODY ASSEMBLY  
 FRAME ASSEMBLY, OIL TANK ASSEMBLY**

	<b>PART NO.</b>	<b>DESCRIPTION</b>	<b>QTY</b>
1	N/A	FRAME ASSEMBLY	1
2	294-002-018	TANK TUBE MOUNTING BRACKET	2
3	01-033	WASHER, #10, EXT TOOTH LOCK, ZINC	16
4	01-019	SCREW, #10-32 X 3/8, PHIL, PAN HEAD, ZINC	4
5	294-002-019	TANK MOUNTING TUBE	1
6	A-0875	TANK LOCK	2
7	01-007	SET SCREW, #10-32 X 1/4, CUP POINT, BLACK	2
8	A-0884	TANK SPACER	5
9	294-002-020	OIL TANK ASSEMBLY, 10" SUMMIT HVO	2
10	SA-0210C	OIL TANK ASSEMBLY, 3"	2
11	SA-0210G	OIL TANK ASSEMBLY, 7"	2

# FRAME ASSEMBLY

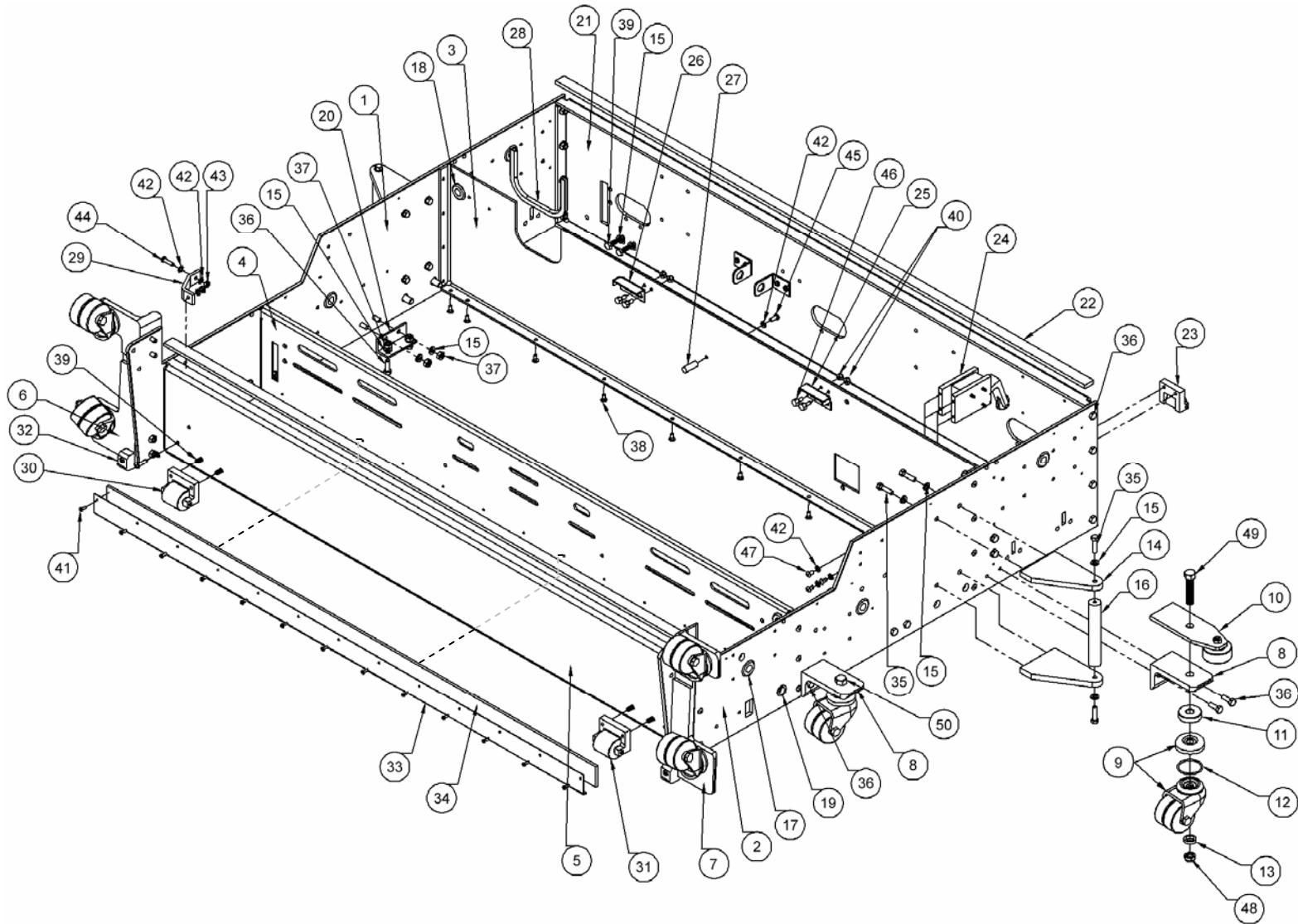

## FRAME ASSEMBLY

	PART NO.	DESCRIPTION
1	294-002-426	LEFT SIDE PLATE
2	294-002-427	RIGHT SIDE PLATE
3	294-002-430	FRONT ELECTRICAL FIREWALL
4	294-002-431	REAR ELECTRICAL FIREWALL
5	294-002-429	REAR PLATE
6	294-002-447	DOUBLE CASTER BRACKET LEFT
7	294-002-446	DOUBLE CASTER BRACKET RIGHT
8	294-002-445	CASTER BRACKET
9	04-292	DOUBLE CASTER W/ DUST CUP
10	294-002-419*	CENTERING GUIDE PLATE ASSY
11	A-0919	CASTER SPACER - THICK
12	04-332	O-RING 1 3/8 ID X 3/32 WALL
13	A-0794	CASTER SPACER
14	294-002-458	HANDLE MOUNT
15	01-054	WASHER, 1/4, SPLIT, ZINC
16	A-0148	END HANDLE
17	711-504-047	GROMMET, 1/4 THICK X 1/2 ID
18	711-504-046	GROMMET, 1/8 THICK X 1/2 ID
19	A-5547	BEARING STUD BUSHING
20	A-0588	FRAME BRACKET
21	294-002-424	FRONT PLATE ASSM
22	04-074	AIRTEX FOAM TAPE 1/4 X 3/4 X 43
23	SA-3012	DUSTER END PLATE ROLLER
24	294-002-136*	TRIP ARM ASSEMBLY
25	A-0342	WASTE TANK LOCK - RIGHT

	PART NO.	DESCRIPTION
26	A-0343	WASTE TANK LOCK - LEFT
27	A-0341	TANK SUPORT
28	04-069	EDGE TRIM
29	294-002-085	OIL COMPARTMENT BRACKET
30	SA-0175	ROLLER ASSEMBLY - LEFT
31	SA-0176	ROLLER ASSEMBLY, RIGHT
32	A-0586	PIVOT CASTER BLOCK
33	B-0505	REAR ELECTRICAL FIREWALL FELT RETAINER
34	A-0031	OIL DRIP FELT
35	01-048	SCREW, 1/4-20 X 1, HEX HEAD, ZINC
36	01-046	SCREW, 1/4-20 X 3/4, HEX HEAD, ZINC
37	01-052	NUT, 1/4-20, HEX, ZINC
38	01-122	POP RIVET, 3/16 DIAMETER X 3/8 LONG, STEEL
39	01-044	SCREW, 1/4-20 X 5/8, HEX HEAD
40	01-031	NUT, #10-32, HEX, NYLON LOCK, ZINC
41	01-130	RIVET, 1/8 X 1/2 LONG, ALUMINUM
42	01-033	WASHER, #10, EXT TOOTH LOCK, ZINC
43	01-032	NUT, #10-32, HEX, ZINC
44	01-023	SCREW, #10-32 X 3/4, PHIL, PAN HD, ZINC
45	01-021	SCREW, #10-32 X 1/2, PHIL, PAN HD, ZINC
46	A-0659	TANK LOCK SHOULDER BOLT
47	01-197	SCREW, #10-32 X 3/8LG, HEX SOCKET BUTTON HEAD
48	01-159	NUT, 7/16-20, NYLON LOCK, THIN
49	809-068-327	SCREW, 7/16-20 X 2 HEX CAP SCREW, ZINC
50	01-385	SCREW, 7/16 X 1 3/4 HEX HEAD BOLT, PLATED

\* For more information, refer to the individual part drawing.

# FRAME ASSEMBLY

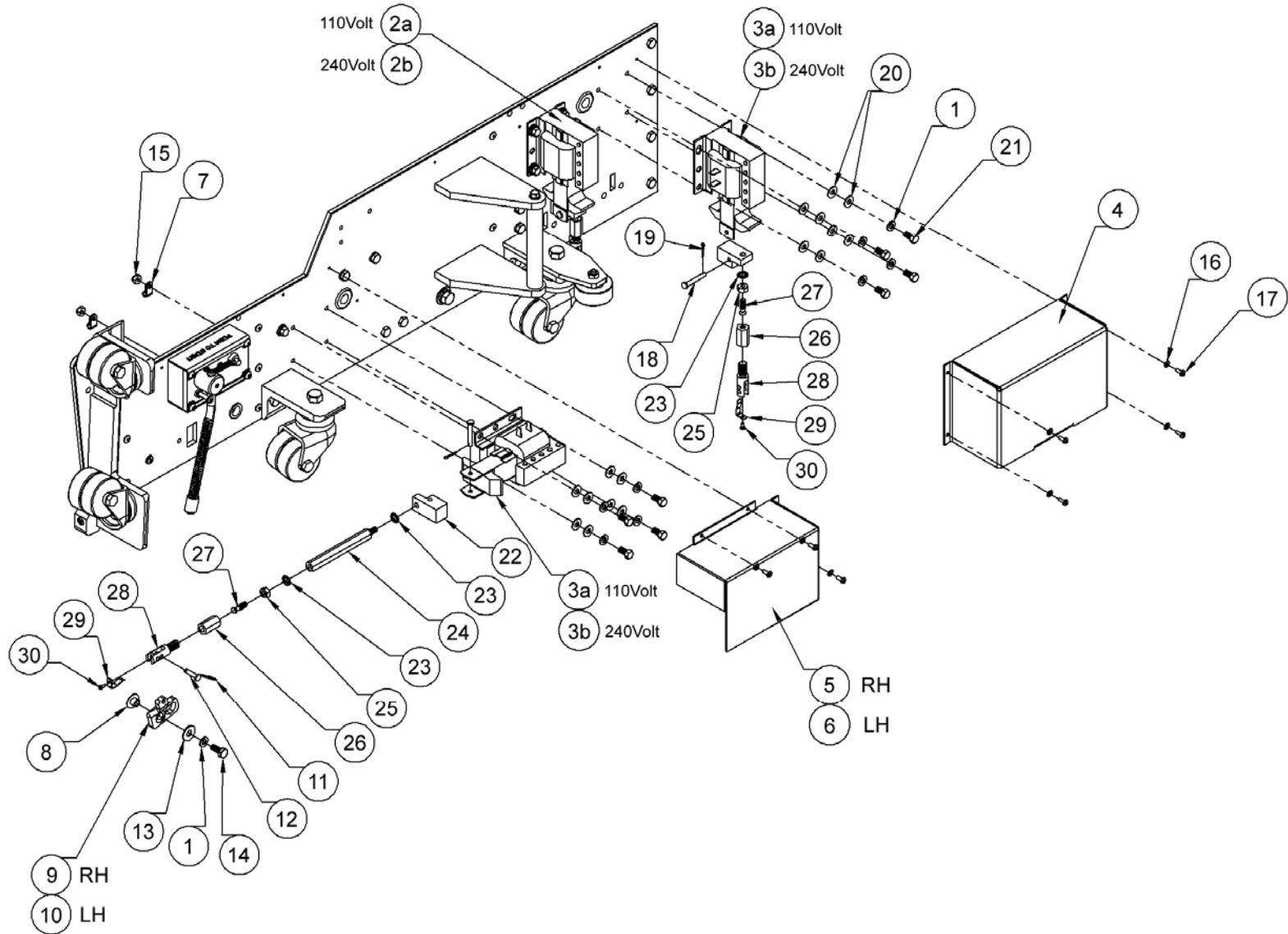

## FRAME ASSEMBLY

	PART NO.	DESCRIPTION
1	01-054	WASHER, 1/4, SPLIT, ZINC
2a	294-002-032	SOLENOID, 110V, 3000 SERIES, RH TERMINALS, 60 Hz
2b	294-002-275	SOLENOID, 240V, 3000 SERIES, RH TERMINALS, 50 Hz
3a	294-002-033	SOLENOID, 110V, 3000 SERIES, LH TERMINALS, 60 Hz
3b	294-002-274	SOLENOID, 240V, 3000 SERIES, LH TERMINALS, 50 Hz
4	294-002-433	VACUUM SOLENOID COVER
5	294-002-432	OIL SOLENOID COVER, RIGHT SIDE
6	294-002-434	OIL SOLENOID COVER, LEFT SIDE
7	02-008	PLASTIC WIRE TIE, 3/16
8	A-4041	PRESSURE LINKAGE PIVOT
9	A-4044	PRESSURE LINKAGE - RIGHT
10	A-4045	PRESSURE LINKAGE - LEFT
11	01-040	PIN, 3/64 X 9/16, HAIR CLIP, ZINC
12	01-215	PIN, 3/16 X .75, CLEVIS
13	01-056	WASHER, 1/4 USS, FLAT, ZINC
14	01-044	SCREW, 1/4-20 X 5/8, HEX HEAD
15	01-031	NUT, #10-32, HEX, NYLON LOCK, ZINC
16	01-005	WASHER, #6, EXT TOOTH LOCK, ZINC
17	01-001	SCREW, #6-32 X 3/8, PHIL, ROUND HEAD, ZINC
18	01-495	PIN, 3/16 X 1 1/4, CLEVIS
19	01-080	PIN, 1/16 X 1/2, COTTER, ZINC
20	01-036	WASHER, 3/16, USS, FLAT
21	01-115	SCREW, 1/4-20 X 1/2, HEX HEAD, ZINC
22	A-8328	SOLENOID LINKAGE BLOCK
23	01-053	WASHER, 1/4, EXT TOOTH LOCK
24	A-0344	BUFFER LINKAGE EXTENSION
25	01-214	NUT, 1/4-28, HEX MACHINE NUT, STEEL, PLATED
26	A-4036	PRESSURE ADJ NUT
27	A-4037	PRESSURE ADJ SWIVEL
28	A-4038	PRESSURE LINKAGE ROD
29	A-4055	DETENT SPRING
30	01-135	SCREW, #4 X 1/4, PAN HEAD SCREW, PHIL

# FRAME ASSEMBLY

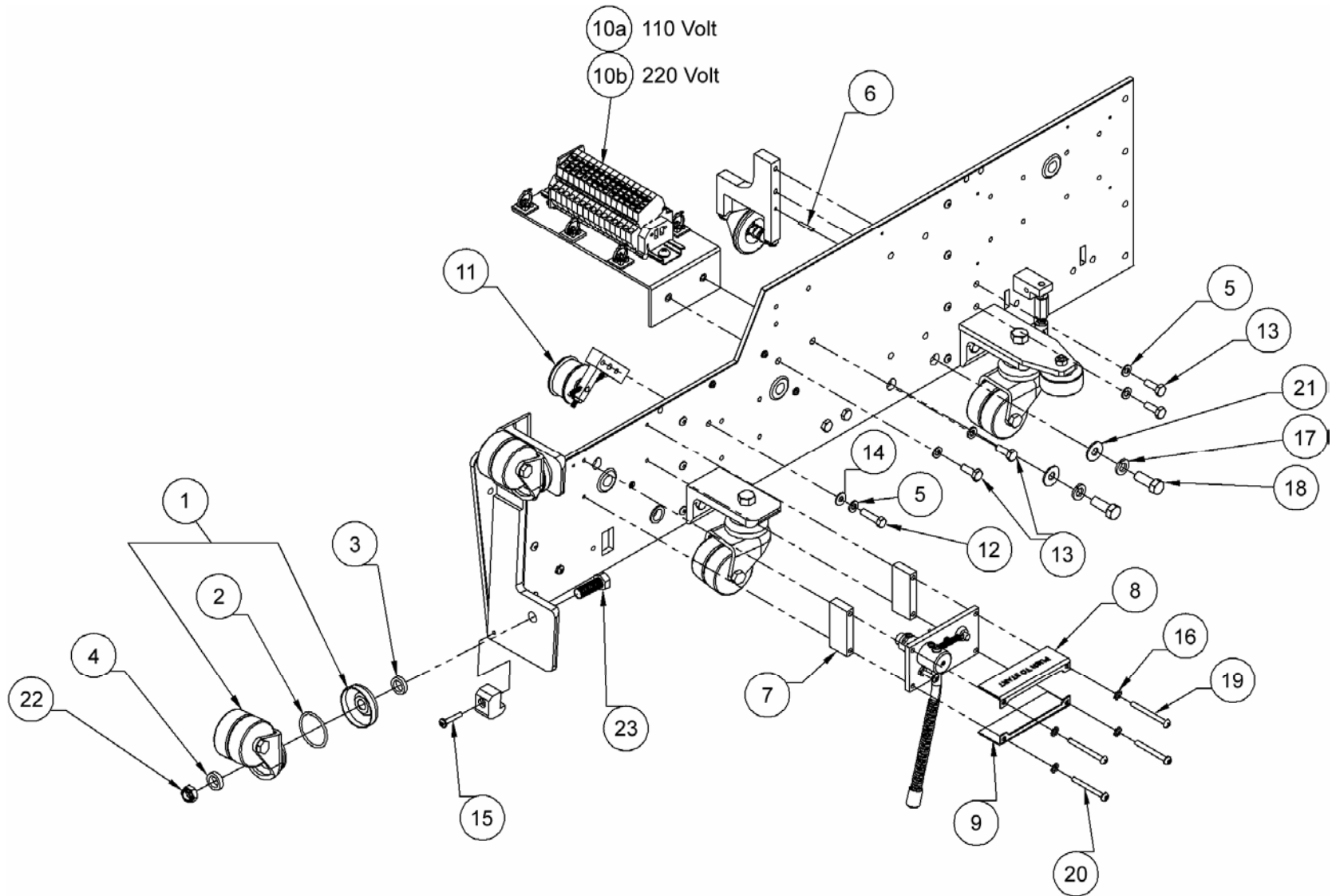



## FRAME ASSEMBLY

	PART NO.	DESCRIPTION
1	04-292	DOUBLE CASTER W/ DUST CUP
2	04-332	O-RING 1 3/8 ID X 3/32 WALL
3	A-00371	SPACER, .750 OD X .510 ID X .160 THICK
4	A-0794	CASTER SPACER
5	01-054	WASHER, 1/4, SPLIT, ZINC
6	01-078	ROLL PIN, 1/8 X 3/4
7	294-002-442	STARTER BOX END
8	294-002-443	STARTER BOX TOP COVER
9	294-002-444	STARTER BOX COVER
10a	294-002-356	FUSE BLOCK ASSEMBLY 110V
10b	294-002-238	FUSE BLOCK ASSEMBLY 220V
11	SA-6516R	IDLER ASSEMBLY, RIGHT
12	01-048	SCREW, 1/4-20 X 1, HEX HEAD, ZINC
13	01-046	SCREW, 1/4-20 X 3/4, HEX HEAD, ZINC
14	01-036	WASHER, 3/16, USS, FLAT
15	01-025	SCREW, #10-32 X 1", SLOTTED PAN HEAD
16	01-033	WASHER, #10, EXT TOOTH LOCK, ZINC
17	01-070	WASHER, 3/8, SPLIT, BRIGHT ZINC
18	01-066	SCREW, 3/8-16 X 1, HEX HEAD, BRIGHT ZINC
19	01-155	SCREW, #10-32 X 2, ROUND HEAD MACHINE SCREW
20	01-392	SCREW, 10-32 X 1 3/4 PAN HEAD MACHINE SCREW
21	01-065	WASHER, 5/16, A, FLAT
22	01-159	NUT, 7/16-20, NYLON LOCK, THIN
23	01-337	SCREW, 7/16 X 1 1/4 HEX HEAD BOLT, PLATED

# FRAME ASSEMBLY

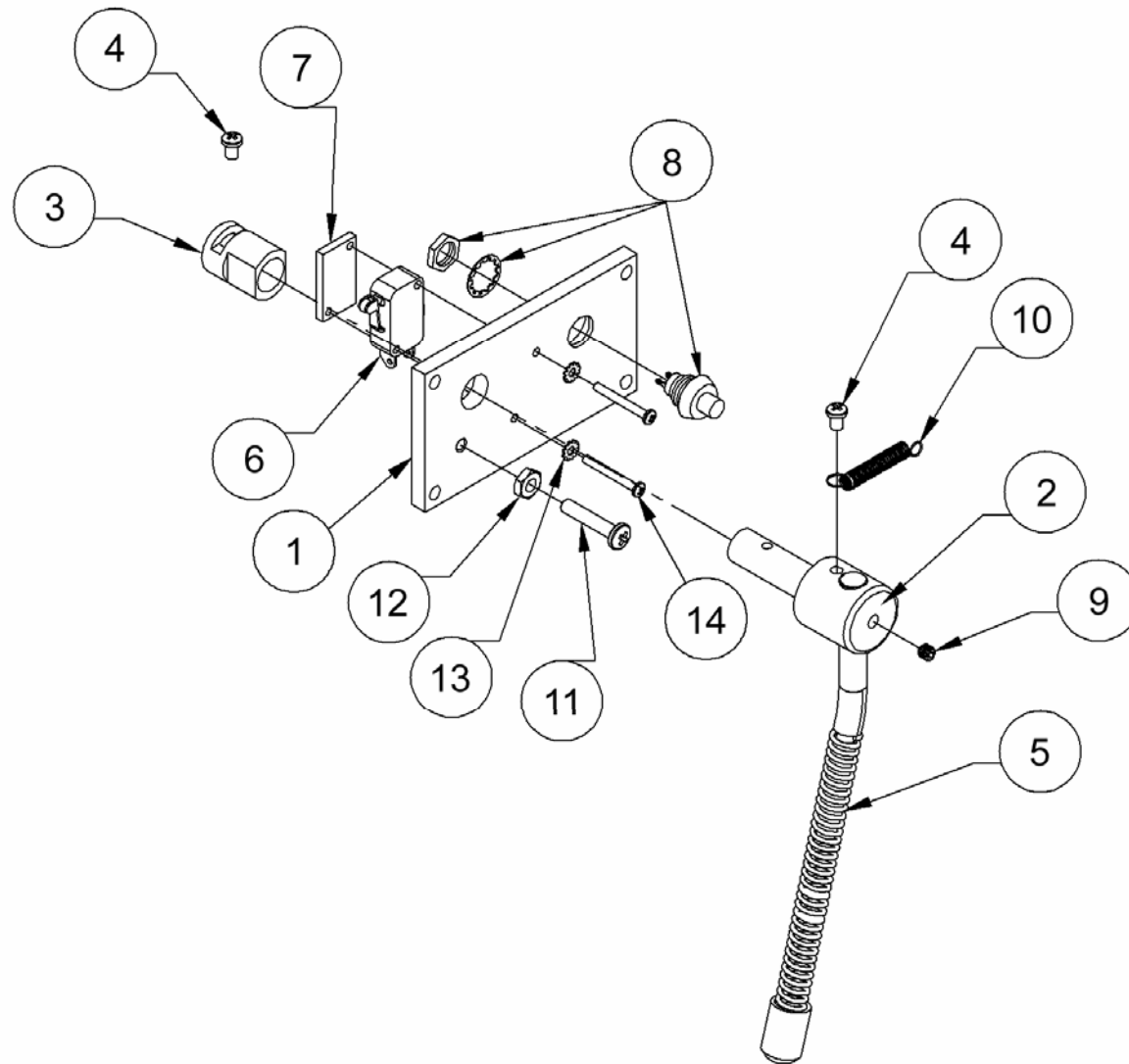

## FRAME ASSEMBLY

	<b>PART NO.</b>	<b>DESCRIPTION</b>
1	294-002-441	STARTER BOX FRONT
2	B-0107	SHUT OFF SHAFT
3	A-0109	SHUT OFF CAM
4	01-008	SCREW, #8-32 X 1/4, PHIL, PAN HEAD
5	SA-1049	SHUT OFF ARM ASSY
6	02-293	MICRO SWITCH
7	A-0445	START SWITCH BACK PLATE
8	02-335	SWITCH
9	01-029	SET SCREW, #10-32 X 3/16, CUP POINT, BLACK FINISH
10	A-0113	SPRING, EXTENSION
11	01-025	SCREW, #10-32 X 1", SLOTTED PAN HEAD
12	01-032	NUT, #10-32, HEX, ZINC
13	01-402	WASHER, #4 EXT TOOTH
14	01-136	SCREW, #4-40 X 1, SLOT, PAN HEAD, ZINC

# BODY ASSEMBLY OIL TANK LINKAGE SYSTEM

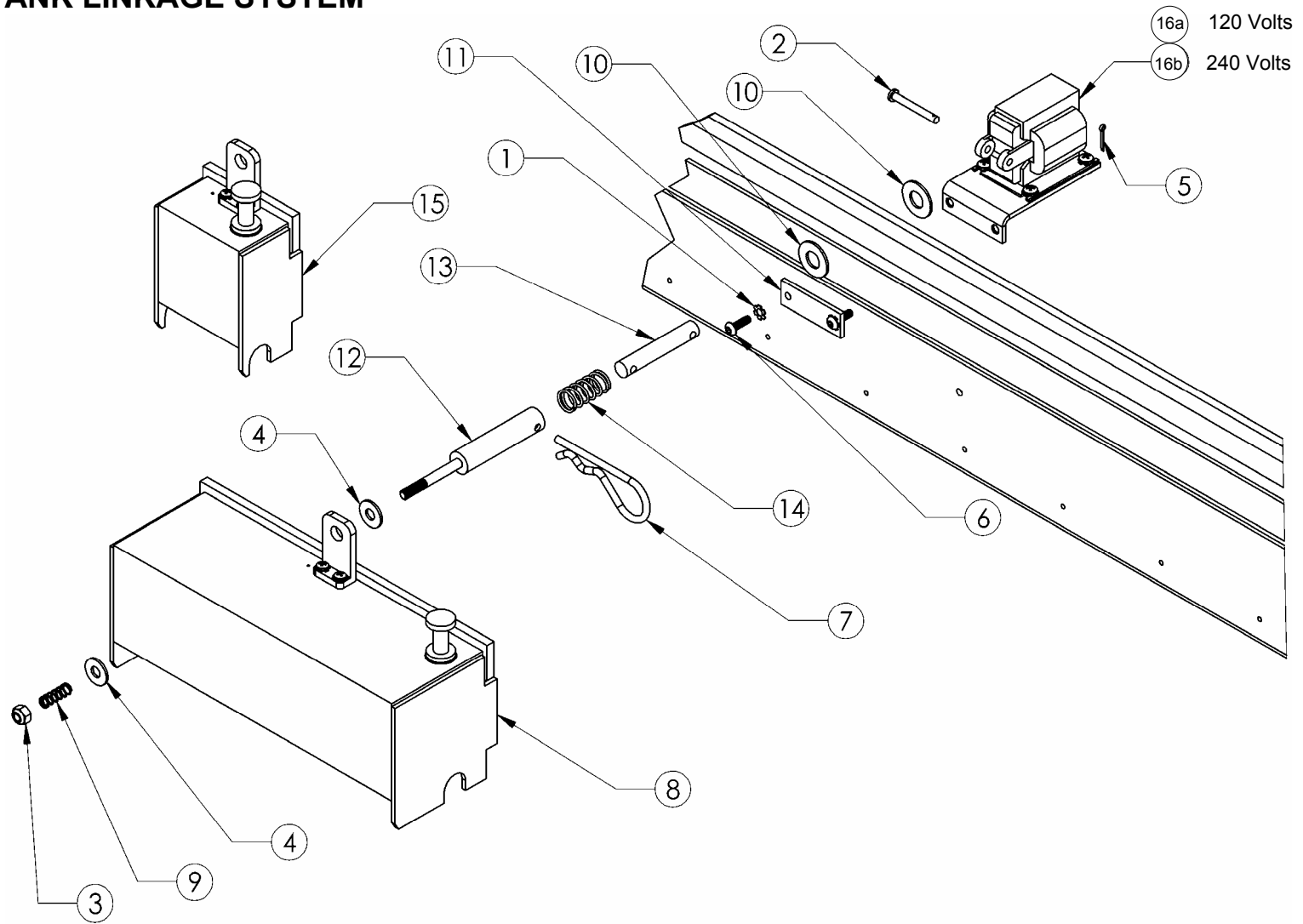

**BODY ASSEMBLY  
OIL TANK LINKAGE SYSTEM**

	<b>PART NO.</b>	<b>DESCRIPTION</b>	<b>QTY</b>
1	01-033	LOCK WASHER, #10 EXTERNAL TOOTH	2
2	01-038	CLEVIS PIN, 3/16 X 1 1/2	1
3	01-051	LOCK NUT, 1/4-20 NYLON INSERT	1
4	01-056	FLAT WASHER, 1/4 USS	2
5	01-080	COTTER PIN, 1/16 X 1/2	1
6	01-608	SCREW, 10-32 X 5/8, HEX SOCKET, BUTTON HEAD	2
7	294-001-007	HITCH PIN	1
8	294-002-020*	OIL TANK ASSEMBLY, 10", HIGH CAPACITY, HIGH OUTPUT	1
9	294-002-174	OIL TANK LINKAGE SPRING	1
10	A-0403	LINKAGE WASHER	2
11	A-0408	SOLENOID MOUNT STIFFENER	1
12	A-0603	TANK PULL ROD	1
13	A-0885	OIL SOLENOID LINKAGE	1
14	A-5038	OIL TANK RETURN SPRING	1
15	SA-0210*	OIL TANK ASSEMBLY	1
16a	SA-3039*	OIL SOLENOID ASSEMBLY, 120V	1
16b	SA-3051*	OIL SOLENOID ASSEMBLY, 240V	1

\* For more information, refer to the individual part drawing.

**SA-3039 OIL SOLENOID ASSEMBLY, 120V**  
**SA-3051 OIL SOLENOID ASSEMBLY, 240V**

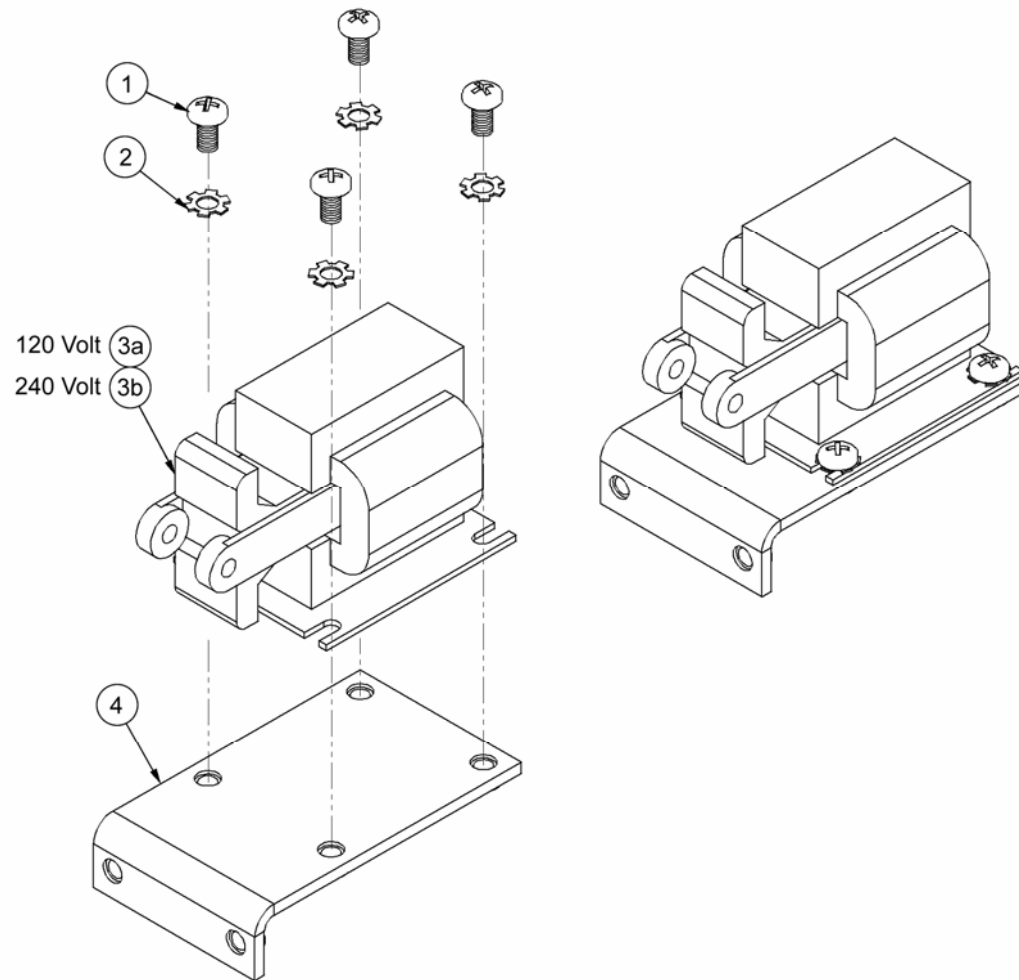

**SA-3039 OIL SOLENOID ASSEMBLY, 120V**  
**SA-3051 OIL SOLENOID ASSEMBLY, 240V**

	<b>PART NO.</b>	<b>DESCRIPTION</b>	<b>QTY</b>
1	01-019	SCREW, 10-32 X 3/8 PAN HEAD	4
2	957-100-002	LOCK WASHER, #10 EXTERNAL TOOTH	4
3a	294-002-031	SOLENOID, 2000 SERIES, LH, 120V, 60HZ	1
3b	294-002-276	SOLENOID, 2000 SERIES, LH, 240V, 50HZ	1
4	A-0674	OIL SOLENOID BRACKET	1

# 294-002-064 OIL TANK ASSEMBLY CONFIGURATIONS

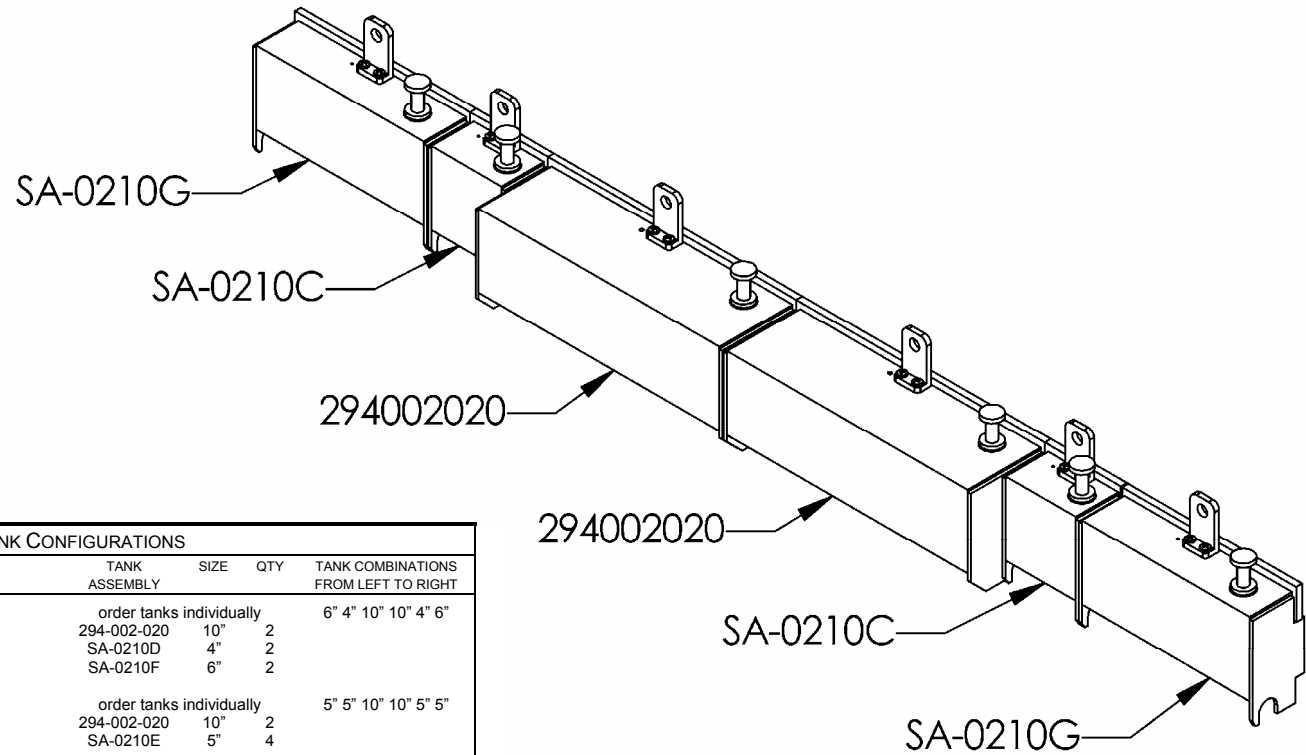

OTHER OIL TANK CONFIGURATIONS							
TANK ASSEMBLY	SIZE	QTY	TANK COMBINATIONS FROM LEFT TO RIGHT	TANK ASSEMBLY	SIZE	QTY	TANK COMBINATIONS FROM LEFT TO RIGHT
294-002-064*	Std with Summit		7" 3" 10" 10" 3" 7"	order tanks individually			6" 4" 10" 10" 4" 6"
294-002-020	10"	2		294-002-020	10"	2	
SA-0210C	3"	2		SA-0210D	4"	2	
SA-0210G	7"	2		SA-0210F	6"	2	
order tanks individually			7" 3" 10" 10" 4" 6"	order tanks individually			5" 5" 10" 10" 5" 5"
294-002-020	10"	2	or	294-002-020	10"	2	
SA-0210C	3"	1	6" 4" 10" 10" 3" 7"	SA-0210E	5"	4	
SA-0210D	4"	1		order tanks individually			6" 4" 10" 10" 5" 5"
SA-0210F	6"	1		294-002-020	10"	2	or
SA-0210G	7"	1		SA-0210D	4"	1	5" 5" 10" 10" 4" 6"
order tanks individually			7" 3" 10" 10" 5" 5"	SA-0210E	5"	2	
294-002-020	10"	2	or	SA-0210F	6"	1	
SA-0210C	3"	1	5" 5" 10" 10" 3" 7"				
SA-0210E	5"	2					
SA-0210G	7"	1					

\* complete set, standard with Summit



**294-002-064**

**OIL TANK ASSEMBLY CONFIGURATIONS**

	<b>PART NO.</b>	<b>DESCRIPTION</b>	<b>QTY</b>
1	SA-0210C	OIL TANK ASSEMBLY, 3"	2
2	SA-0210G	OIL TANK ASSEMBLY, 7"	2
3	294-002-020	OIL TANK ASSEMBLY, 10", HIGH CAPACITY, HIGH OUTPUT	2

**SA-0210  
OIL TANK ASSEMBLY**

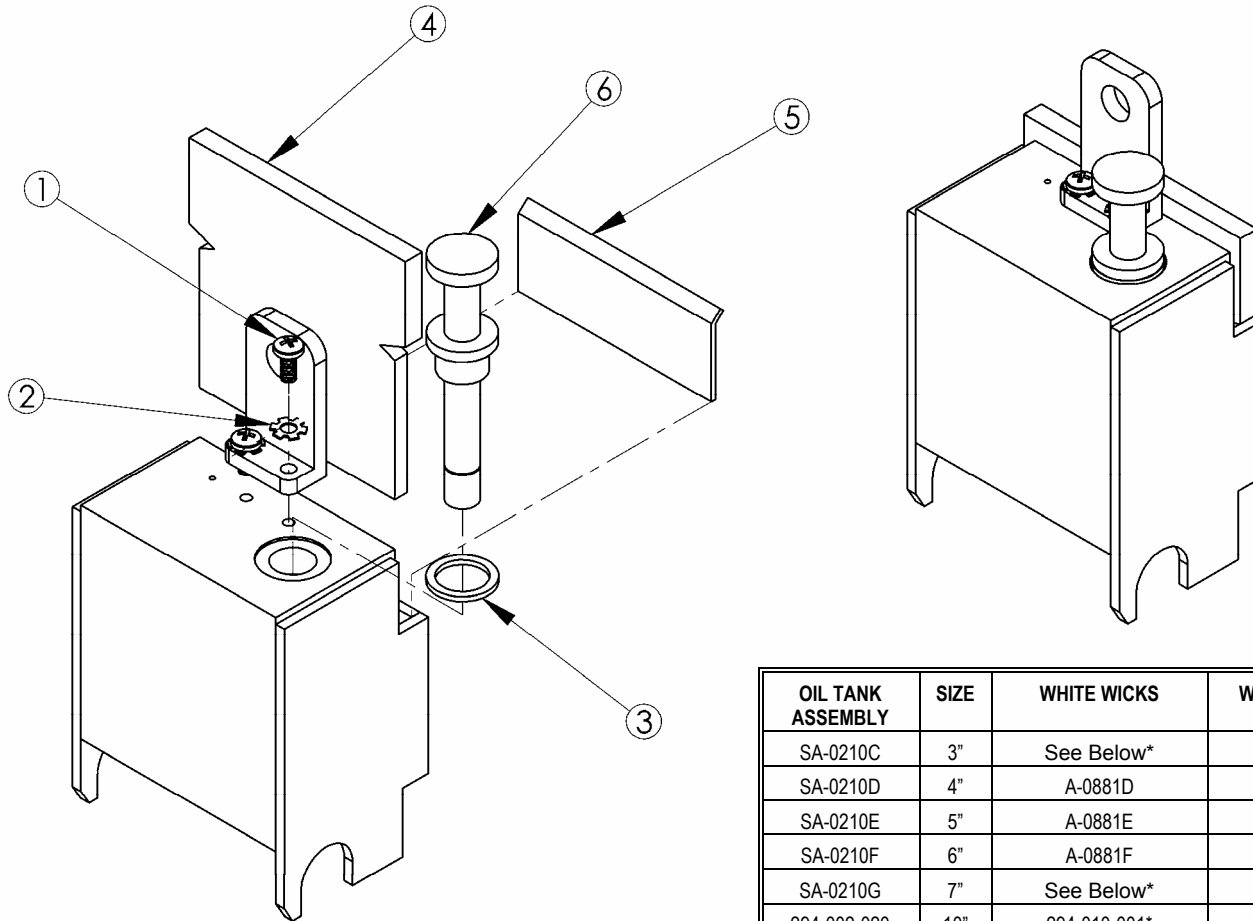

OIL TANK ASSEMBLY	SIZE	WHITE WICKS	WICK RETAINERS
SA-0210C	3"	See Below*	NONE
SA-0210D	4"	A-0881D	A-0882D
SA-0210E	5"	A-0881E	A-0882E
SA-0210F	6"	A-0881F	A-0882F
SA-0210G	7"	See Below*	NONE
294-002-020	10"	294-010-001*	NONE
612-551-001*	HVO Wick Kit consisting of two 10", two 7", and two 3" wicks		

\* The 3" and 7" wicks are available along with the 10" wicks in 612-551-001.

**SA-0210**  
**OIL TANK ASSEMBLY**

	<b>PART NO.</b>	<b>DESCRIPTION</b>	<b>QTY</b>
1	01-009	SCREW, 8-32 X 3/8 PAN HEAD	2
2	951-632-060	LOCK WASHER, #8 EXTERNAL TOOTH	2
3	04-093	WASHER	1
4	A-0881*‡	WICK, WHITE	1
5	A-0882‡	WICK RETAINER	1
6	SA-0213	DIPSTICK ASSEMBLY	1

\* To order a complete wick set for the standard oil tank configuration, see page A-22.

‡ To order individual wicks and wick retainers, see previous page.

\* To order individual tanks and to see other available tank sizes, see page A-22 or A-24.

**294-002-020**  
**OIL TANK ASSEMBLY (10" HVO)**

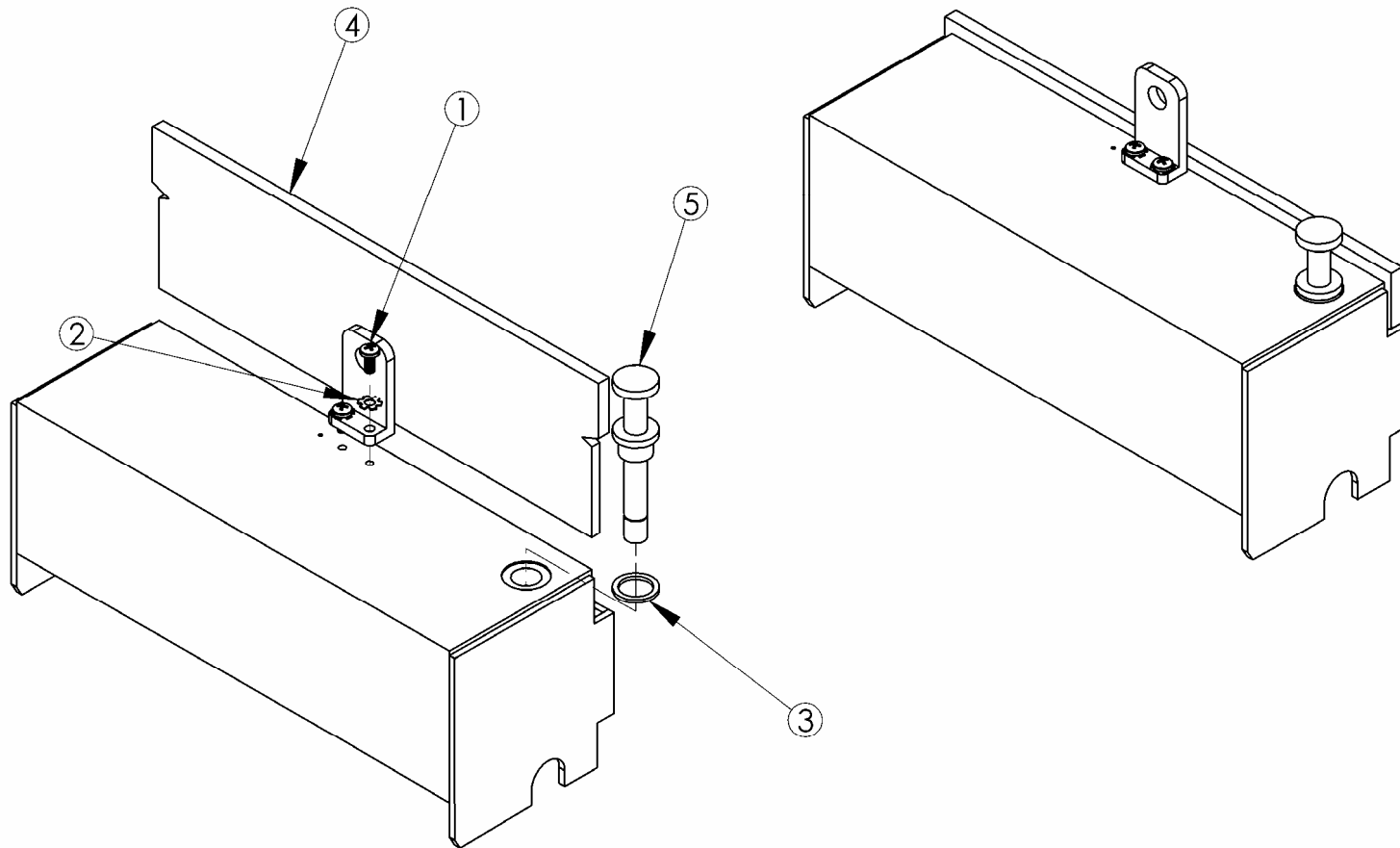

**294-002-020****OIL TANK ASSEMBLY (HVO)**

	<b>PART NO.</b>	<b>DESCRIPTION</b>	<b>QTY</b>
1	01-009	SCREW, 8-32 X 3/8 PAN HEAD	2
2	951-632-060	LOCK WASHER, #8 EXTERNAL TOOTH	2
3	04-093	WASHER	1
4	294-010-001	WICK, 10", WHITE HIGH FLOW	1
5	SA-0213	DIPSTICK ASSEMBLY	1

\* To order individual wicks, see page A-24.

\* To order a complete wick set, see page A-24.

**294-002-070**  
**TRANSFER ROLLER ASSEMBLY**

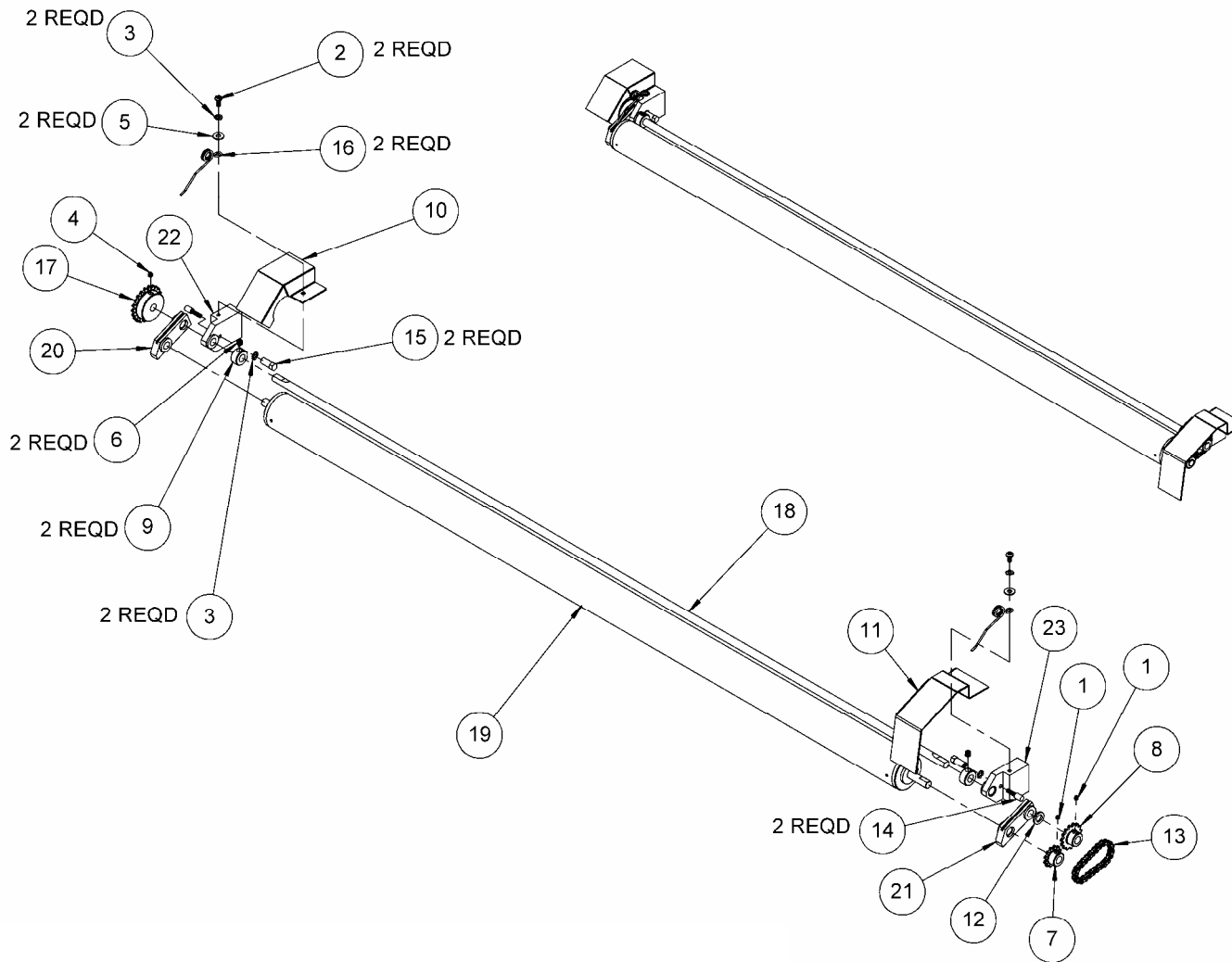

**294-002-070****TRANSFER ROLLER ASSEMBLY**

	<b>PART NO.</b>	<b>DESCRIPTION</b>	<b>QTY</b>
1	01-006	SET SCREW, 8-32 X 3/16 HEX SOCKET HEAD, CUP POINT	2
2	01-009	SCREW, 8-32 X 3/8 PAN HEAD	2
3	951-632-060	LOCK WASHER, #8 EXTERNAL TOOTH	4
4	01-098	SET SCREW, 10-32 X 3/8 HEX SOCKET HEAD, CUP POINT	1
5	01-109	FLAT WASHER, #8 USS	2
6	01-586	SET SCREW, 1/4-20 X 3/16 HEX SOCKET HEAD, CUP POINT	2
7	03-001	SPROCKET, #25 CHAIN, 12 TOOTH, 3/8 BORE	1
8	03-007	SPROCKET, #25 CHAIN, 15 TOOTH, 3/8 BORE	1
9	04-015	SET SCREW COLLAR	2
10	294-002-148	TRANSFER ROLLER GUARD	1
11	294-002-149	BUFFER BELT GUARD	1
12	A-0036	ROLLER DRIVE SHAFT WASHER	1
13	A-0071	ROLLER CHAIN	1
14	A-0463	POSITIVE STOP SCREW	2
15	A-0464	POSITIVE STOP NUT	2
16	A-0583	ROLLER SPRING	2
17	A-0951	SPROCKET MODIFICATION	1
18	B-0063	ROLLER DRIVE SHAFT	1
19	SA-0296	ROLLER ASSEMBLY	1
20	SA-1023L	ROLLER SUPPORT ARM ASSEMBLY, LEFT	1
21	SA-1023R	ROLLER SUPPORT ARM ASSEMBLY, RIGHT	1
22	SA-3023L	ROLLER DRIVE SHAFT SUPPORT ARM ASSEMBLY, LEFT	1
23	SA-3023R	ROLLER DRIVE SHAFT SUPPORT ARM ASSEMBLY, RIGHT	1

**294-002-350 (110 VOLT), 294-002-270 (220 VOLT)  
BUFFER MOTOR ASSEMBLY**

	<b>PART NO.</b>	<b>DESCRIPTION</b>	<b>QTY</b>
1	01-041	SET SCREW, 1/4-20 X 1/4 HEX SOCKET HEAD, CUP POINT	1
2	A-0425	PULLEY MODIFICATION	1
3	294-002-268	BUFFER MOTOR (CE)	1
4	294-115-330	GROUND WIRE (REQUIRED FOR 220 VOLT ONLY)	1

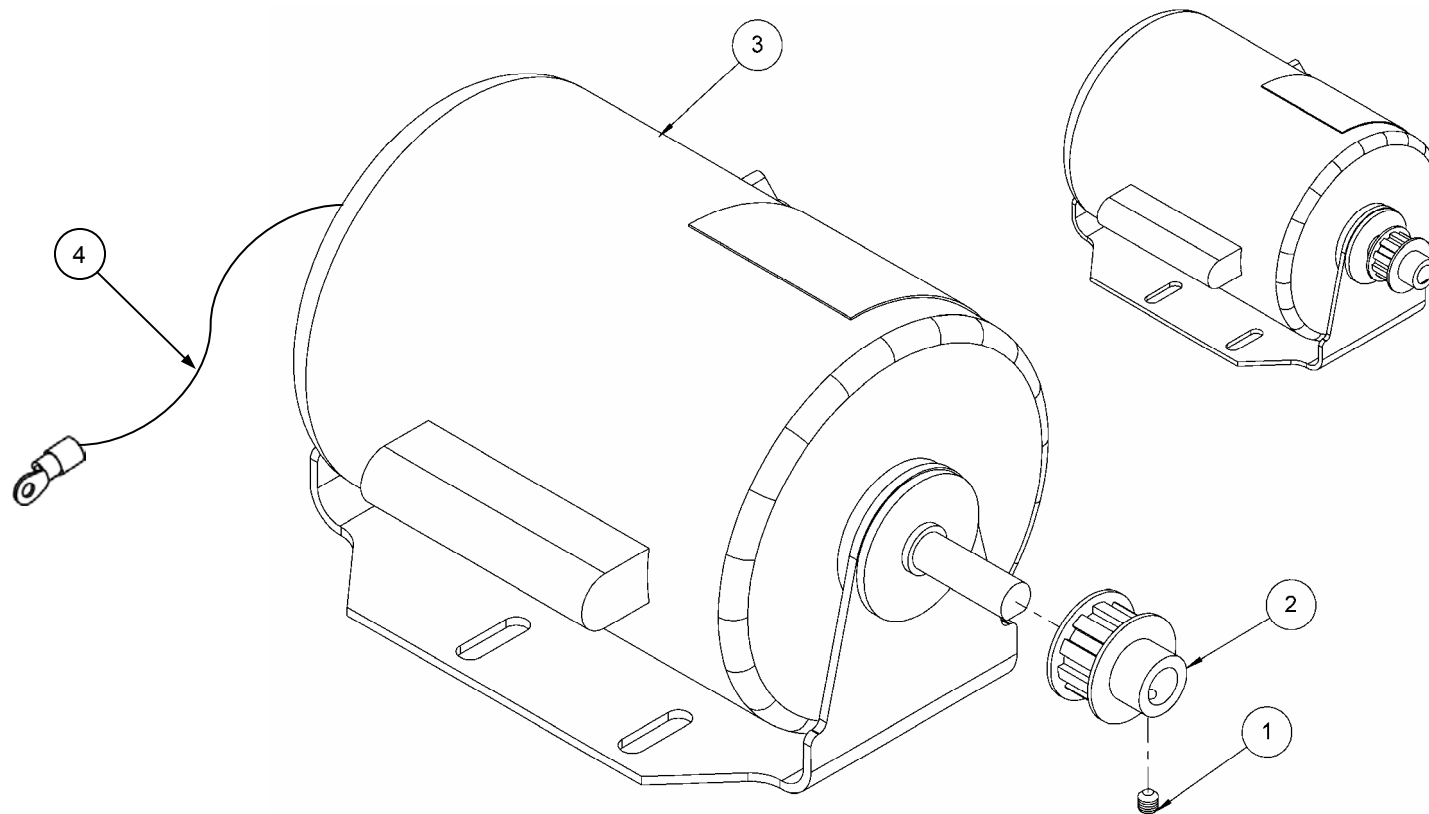



# SA-1182 BRUSH TUBE ASSEMBLY

	PART NO.	DESCRIPTION	QTY
1	01-174	CAP SCREW, 1/4-20 X 1 HEX SOCKET HEAD	1
2	A-0420	BRUSH DRIVE	1

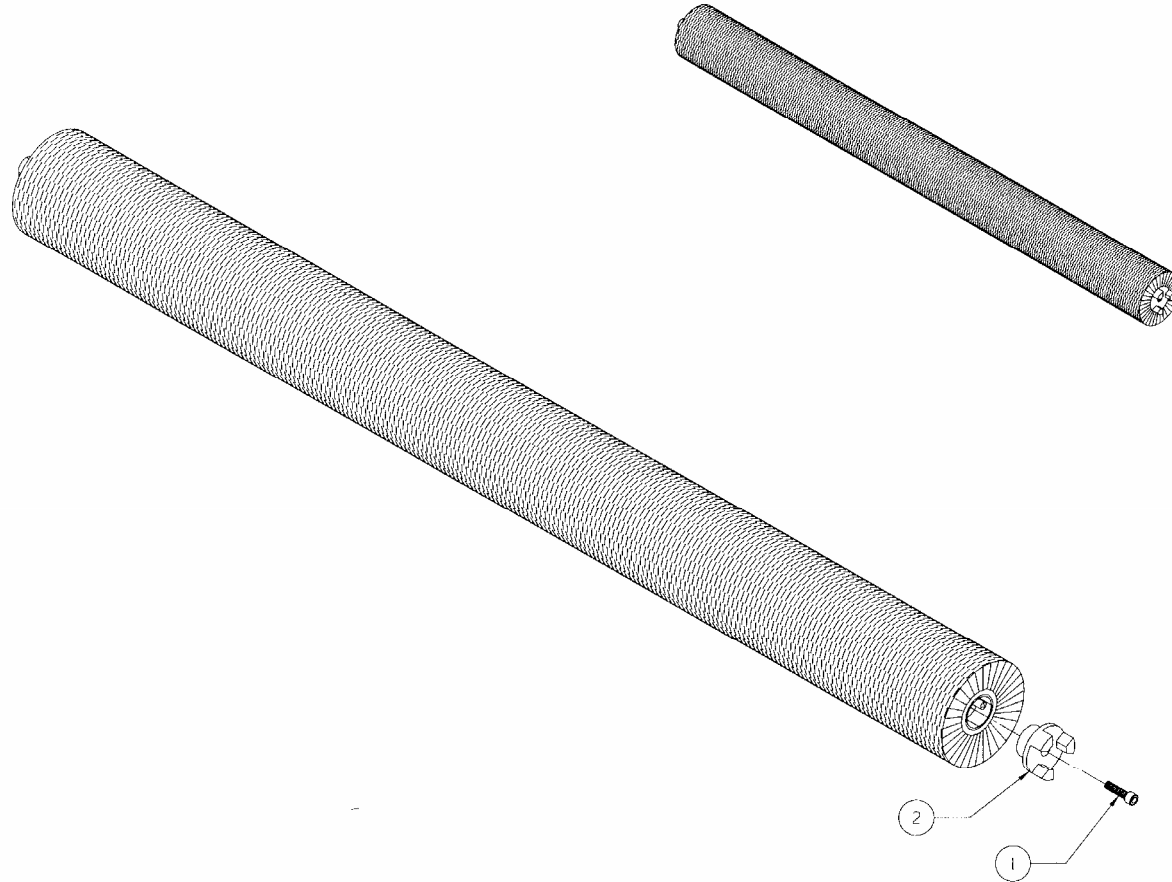

**SA-6516R  
IDLER ASSEMBLY, RIGHT**

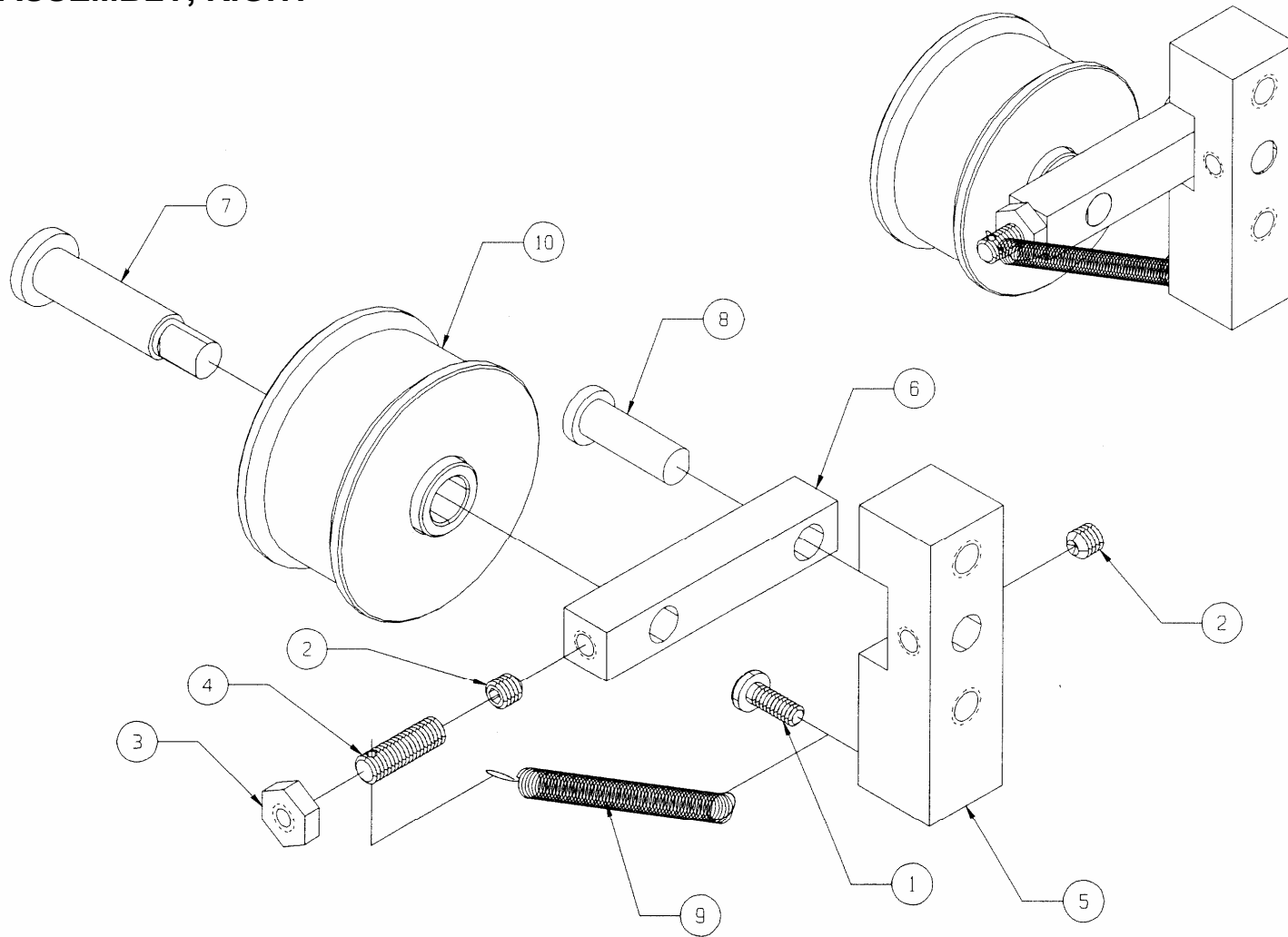

**SA-6516R  
IDLER ASSEMBLY, RIGHT**

	<b>PART NO.</b>	<b>DESCRIPTION</b>	<b>QTY</b>
1	01-001	SCREW, 6-32 X 3/8 ROUND HEAD	1
2	01-029	SET SCREW, 10-32 X 3/16 HEX SOCKET HEAD, CUP POINT	2
3	835-540-002	NUT, 10-32	1
4	A-5061	SOLVENT TUBE SPRING BOLT	1
5	A-5554	IDLER MOUNT BRACKET	1
6	A-5555	IDLER PIVOT ARM	1
7	A-5556	ROLLER PIN	1
8	A-5557	PIVOT ARM PIN	1
9	A-5558	IDLER SPRING	1
10	SA-6534	TENSION PULLEY ASSEMBLY	1

# SA-1105 BUFFER DRIVE ASSEMBLY

	PART NO.	DESCRIPTION	QTY
1	01-008	SCREW, 8-32 X 1/4 PAN HEAD	1
2	A-0079	RUBBER SPIDER	1
3	A-0409	BUFFER RETURN SPRING	1
4	A-5546	BEARING MOUNTING STUD	1

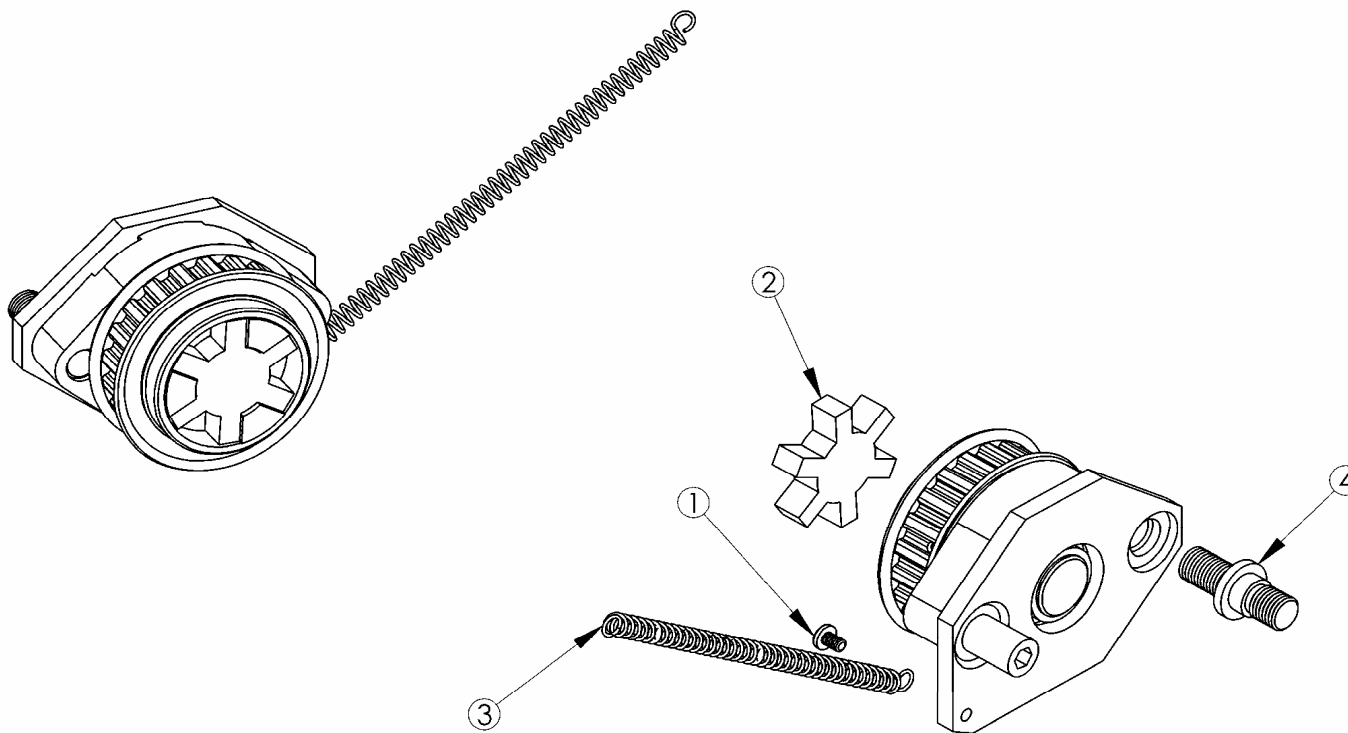

# SA-1106 BUFFER IDLER ASSEMBLY

	PART NO.	DESCRIPTION	QTY
1	01-008	SCREW, 8-32 X 1/4 PAN HEAD	1
2	A-0409	BUFFER RETURN SPRING	1
3	A-5546	BEARING MOUNTING STUD	1

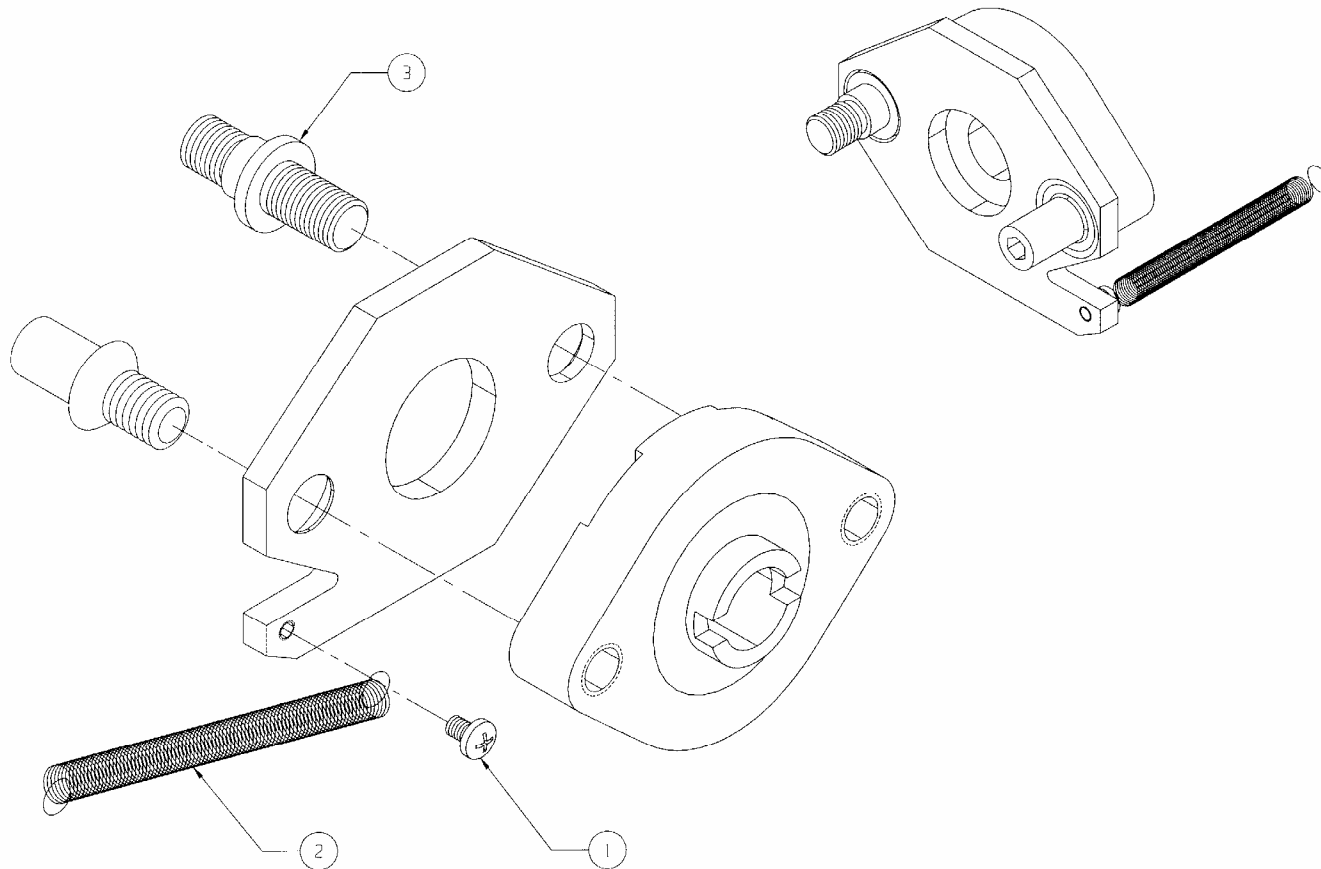

**SA-1227  
OIL FILL BOTTLE**

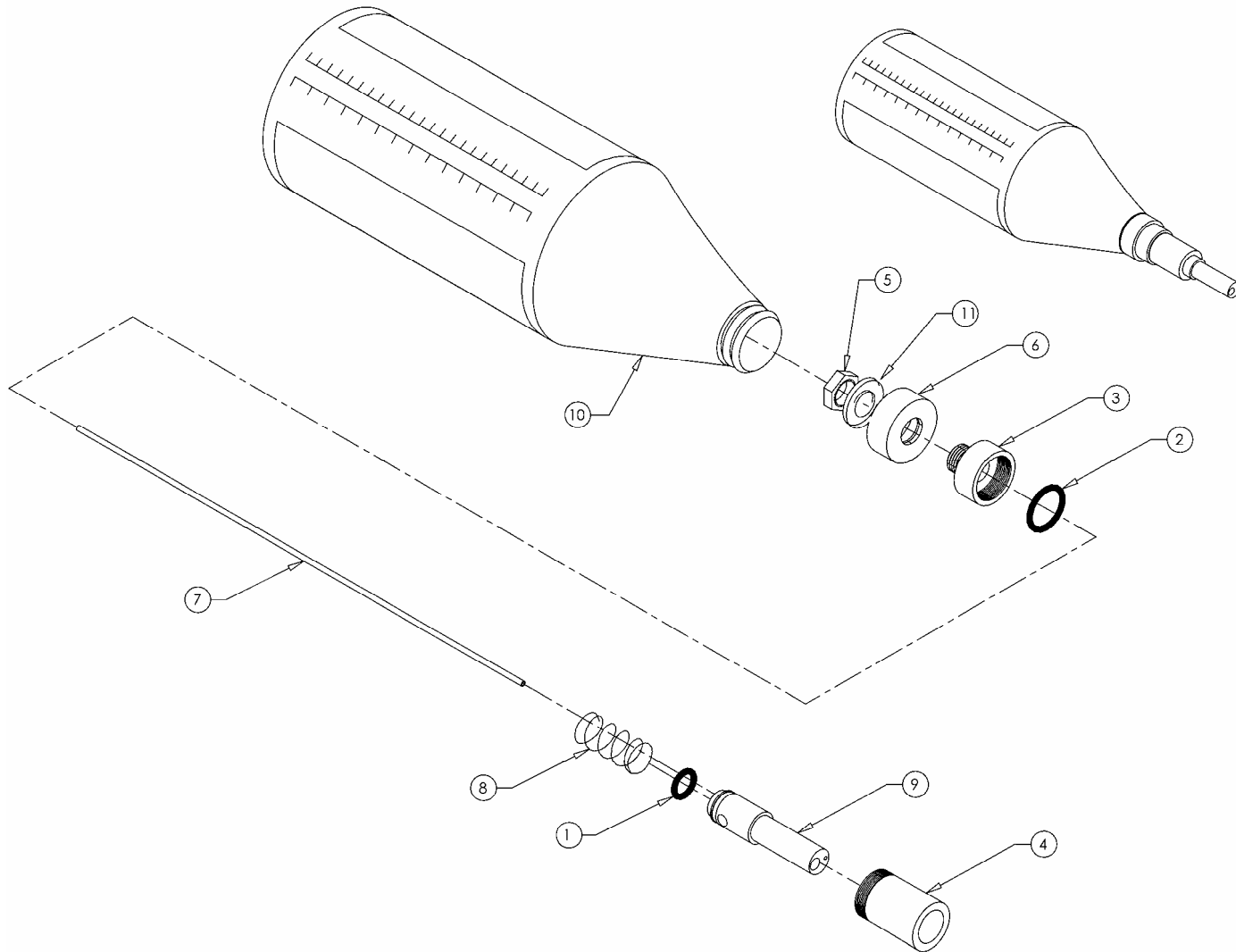

**SA-1227**  
**OIL FILL BOTTLE**

	<b>PART NO.</b>	<b>DESCRIPTION</b>	<b>QTY</b>
1	04-351	O-RING	1
2	04-352	O-RING	1
3	A-0897	CAP ADAPTER	1
4	A-0898	TANK STOP	1
5	A-0900	BOTTLE NUT	1
6	A-0901	BOTTLE CAP MODIFICATION	1
7	A-0902	BREATHER TUBE	1
8	A-0903	OIL BOTTLE RETRACT SPRING	1
9	SA-1229	NOZZLE & PLUG ASSEMBLY	1
10	04-342	PLASTIC BOTTLE	1
11	04-093	WASHER	1

# BODY ASSEMBLY

BRUSH, CLEANER PAD, TRANSFER ROLLER, VACUUM HEAD, VACUUM MOTOR, WASTE TANK

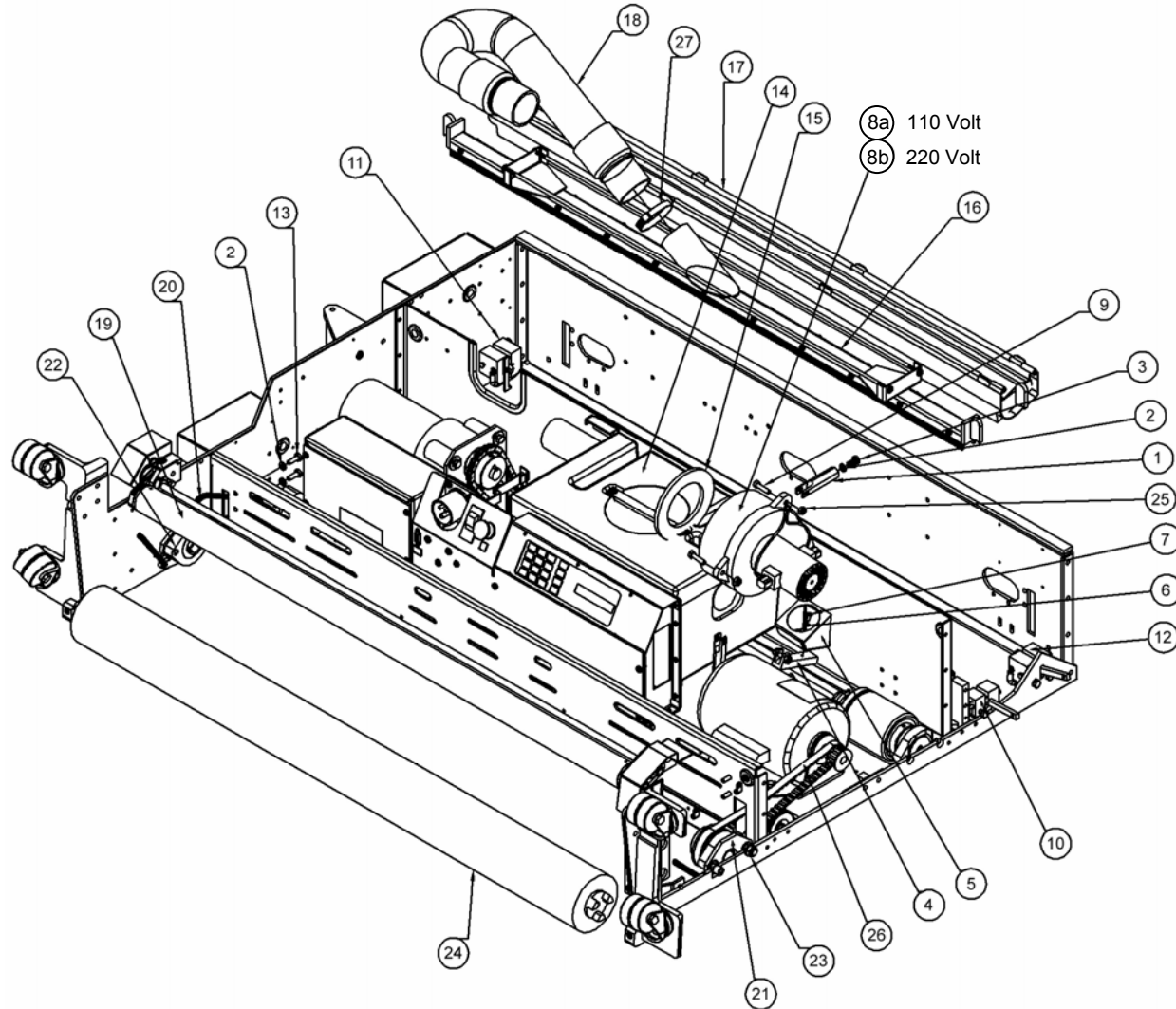



## BODY ASSEMBLY

### BRUSH, CLEANER PAD, TRANSFER ROLLER, VACUUM HEAD, VACUUM MOTOR, WASTE TANK

	PART NO.	DESCRIPTION	QTY
1	A-0338	UPPER VAC MOTOR MOUNT	1
2	01-054	WASHER, 1/4, SPLIT, ZINC	14
3	01-044	SCREW, 1/4-20 X 5/8, HEX HEAD	2
4	A-0405	LOWER VAC MOTOR MOUNT	1
5	A-0406	VAC EXHAUST PLATE	1
6	01-016	WASHER, #8, EXT TOOTH LOCK, ZINC	1
7	01-009	SCREW, #8-32 X 3/8, PHIL, PAN HEAD, ZINC	1
8a	02-214	110V VACUUM MOTOR	1
8b	02-255	220V VACUUM MOTOR	1
9	01-048	SCREW, 1/4-20 X 1, HEX HEAD, ZINC	3
10	SA-0321	VAC-HEAD SLIDE BLOCK MOUNT ASSEMBLY	2
11	294-002-481	CLEANER TRAY MOUNT ASSY	1
12	294-002-482	CLEANER TRAY MOUNT ASSY, RIGHT	1
13	01-046	SCREW, 1/4-20 X 3/4, HEX HEAD, ZINC	12
14	SA-1129	WASTE TANK ASSEMBLY	1
15	A-8307	TANK SEAL	1
16	SA-9032	VAC-HEAD ASSEMBLY	1
17	SA-0256	CLEANER PAD ASSEMBLY	1
18	SA-1101	VACUUM HOSE ASSEMBLY	1
19	294-002-070	TRANSFER ROLLER DRIVE ASSEMBLY	1
20	A-0952	CHAIN #25 14 3/4 LENGTH	1
21	SA-1105	BUFFER DRIVE ASSEMBLY	1
22	SA-1106	BUFFER IDLER ASSEMBLY	1
23	01-159	NUT, 7/16-20, NYLON LOCK, THIN	2
24	SA-1182	BUFFER TUBE ASSEMBLY	1
25	01-051	NUT, 1/4-20, NYLON LOCK, ZINC	9
26	03-099	BUFFER DRIVE BELT	1
27	04-120	CLAMP, WASTE TANK HOSE	1

# FRONT PLATE ASSEMBLY (FRONT VIEW)

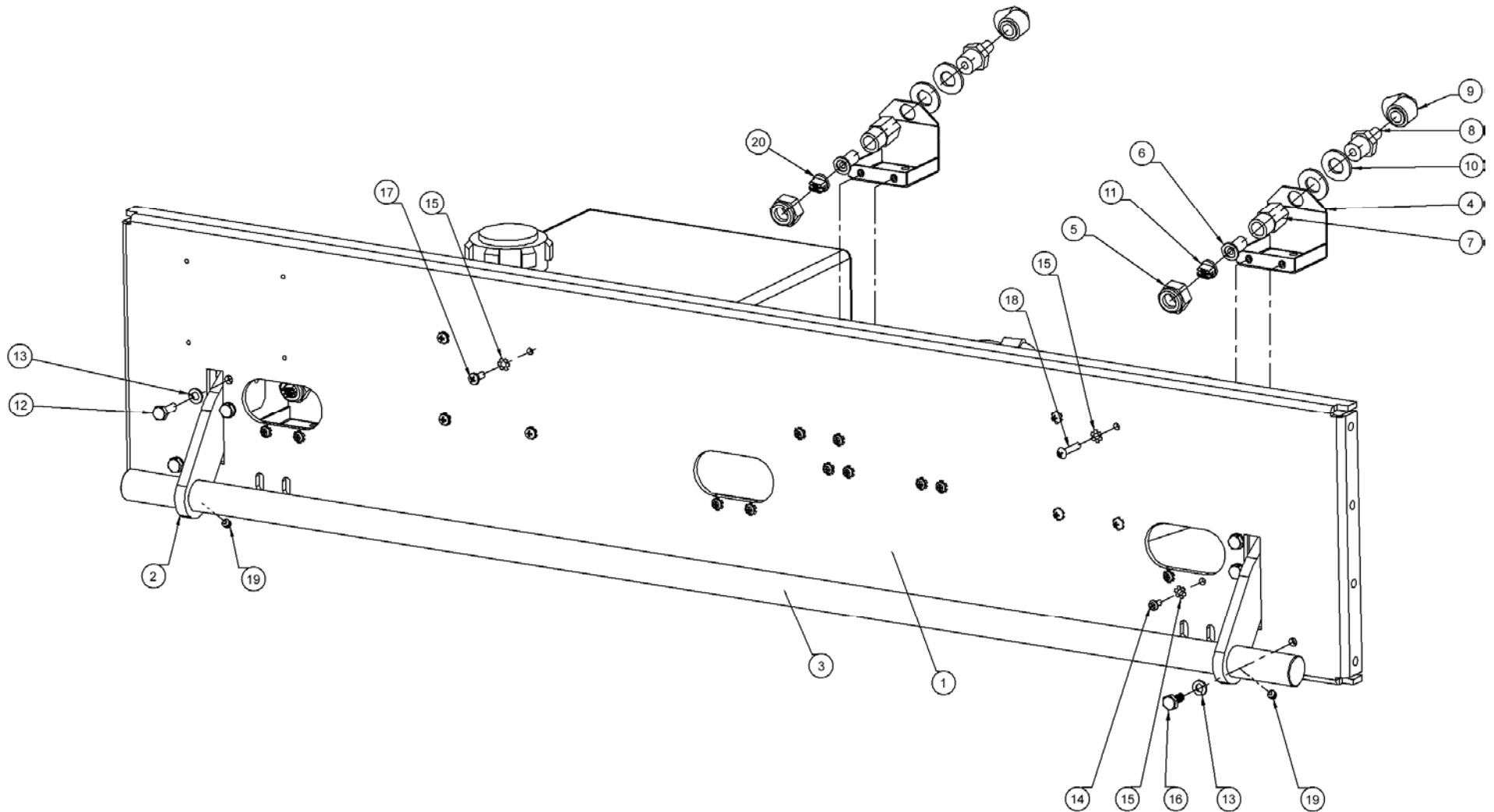

## FRONT PLATE ASSEMBLY (FRONT VIEW)

	PART NO.	DESCRIPTION	QTY
1	294-002-405	FRONT PLATE	1
2	294-002-448	HANDLE HOLDER BRACKET	2
3	294-002-449	HANDLE FRONT	1
4	294-002-402	BRACKET NOZZLE ASSEMBLY	3
5	294-002-404	TIP RETAINER, UNIJET 1325	3
6	294-002-401	STRAINER CHECK VALVE	3
7	294-002-403	NOZZLE BODY	3
8	294-115-072	STEM ADAPTER	6
9	294-115-073	ELBOW, UNION, QUICK CONNECT	5
10	948-975-172	WASHER 17/32 X 1 1/16	6
11	294-002-407	SPRAY NOZZLE, UNIJET 1501 (for use with left or right nozzle assembly only)	2
12	01-046	BOLT, 1/4-20 X 3/4, HEX HEAD	4
13	951-148-002	LOCK WASHER, SPLIT, 1/4	6
14	01-019	SCREW, #10-32 X 3/8	12
15	01-033	LOCK WASHER, #10 EXTERNAL TOOTH	20
16	01-044	BOLT, 1/4-20 X 5/8 HEX HEAD	2
17	01-021	SCREW, #10-32 X 1/2 PAN HEAD	4
18	01-024	SCREW, #10-32 X 1, PHILIPS, ROUND HEAD, ZINC	4
19	01-041	SET SCREW, 1/4-20 X 1/4 CUP POINT	2
20	294-002-406	SPRAY NOZZLE, UNIJET 8003 (for use with center nozzle assembly only)	1

# FRONT PLATE ASSEMBLY (REAR VIEW)

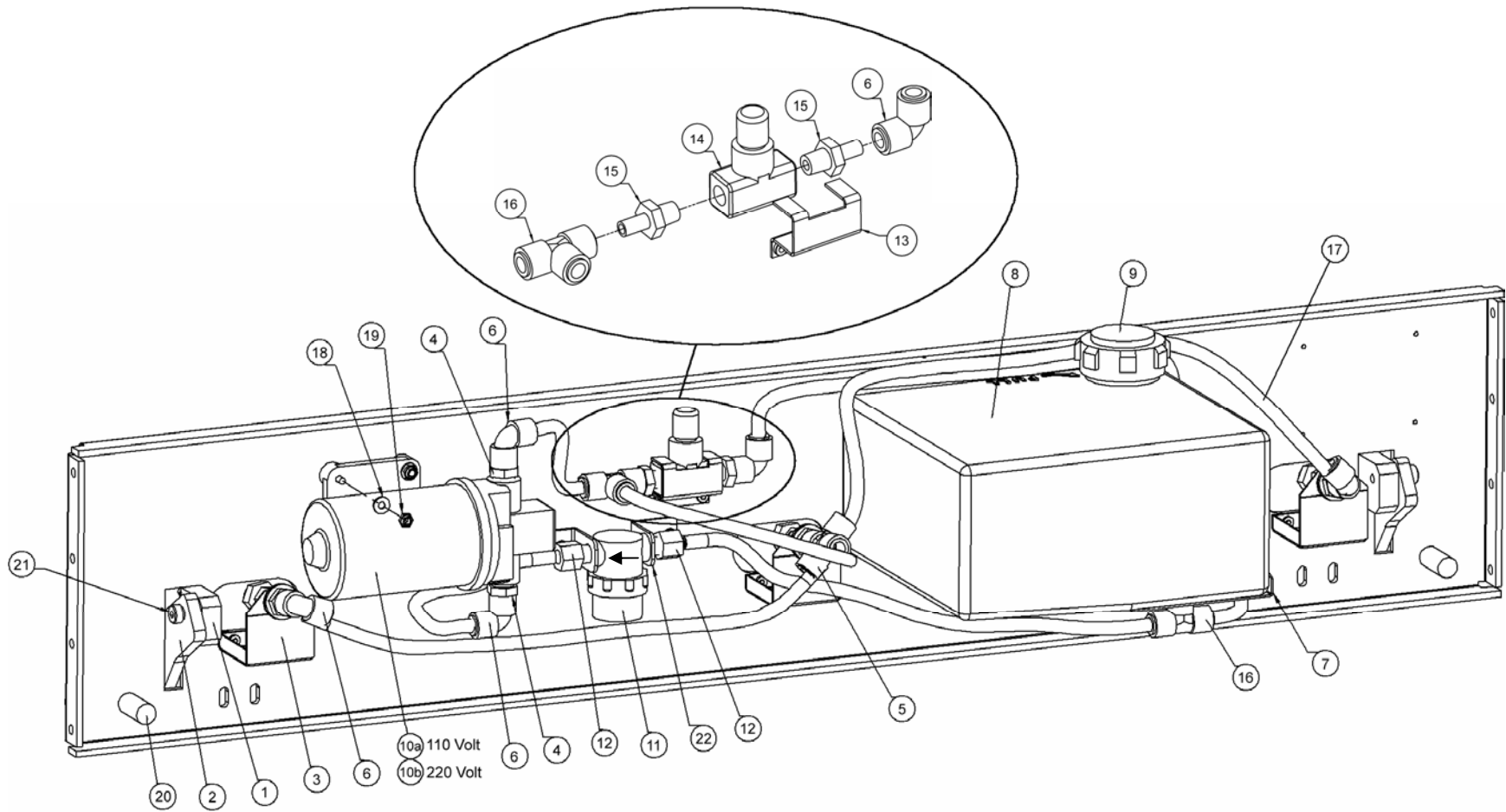

## FRONT PLATE ASSEMBLY (REAR VIEW)

	PART NO.	DESCRIPTION	QTY
1	294-002-453	MOUNTING BRACKET, FRONT HANDLE	2
2	294-002-448	HANDLE HOLDER BRACKET	2
3	294-002-402	BRACKET NOZZLE ASSEMBLY	3
4	294-115-072	STEM ADAPTER	6
5	294-115-076	CROSS, UNION, QUICK CONNECT	1
6	294-115-073	ELBOW, UNION, QUICK CONNECT	5
7	294-002-410	CLEANER TANK BRACKET	1
8	294-115-048	CLEANER TANK	1
9	294-115-092	CLEANER TANK CAP	1
10a	02-206	CLEANER PUMP, 110V	1
10b	294-115-287	CLEANER PUMP, 220V	1
11	04-322	FILTER BOWL	1
12	04-398	FITTING	2
13	294-115-288	CLEANER VALVE BRACKET	1
14	04-112	VOLUME VALVE	1
15	294-115-071	STEM ADAPTER	2
16	294-115-074	TEE, UNION, QUICK CONNECT	2
17	04-128	TUBE, TYGOTHANE (SPECIFY LENGTH IN FEET)	1
18	01-030	WASHER, #10 FLAT	4
19	838-740-002	NUT, #10-32, HEX, LOCK	4
20	A-8346	TRAY DIRECTION BLOCK	2
21	880-164-720	SCREW, 3/8 X 1/2 SHOULDER BOLT	2
22	A-0975	BRACKET, FILTER MOUNT	2

# CLEANER TANK ASSEMBLY

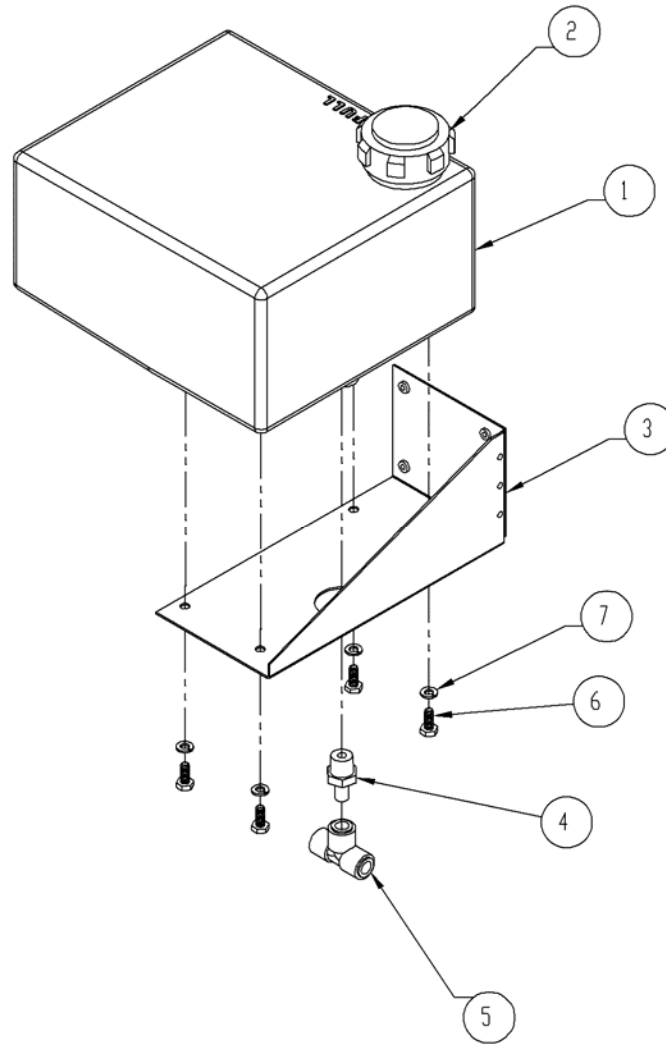

## CLEANER TANK ASSEMBLY

	PART NO.	DESCRIPTION	QTY
1	294-115-048	CLEANER TANK	1
2	294-115-092	CLEANER TANK CAP	1
3	294-001-410	BRACKET, CLEANER TANK	1
4	294-115-072	STEM ADAPTER, 3/8 MPT X 3/8	1
5	294-115-074	UNION TEE – 3/8 X 3/8, QUICK CONNECT	2
6	01-044	SCREW, 1/4-20 X 5/8, HEX HEAD	6
7	01-054	WASHER, 1/4, SPLIT, ZINC	4

# FILTER MOUNT ASSEMBLY

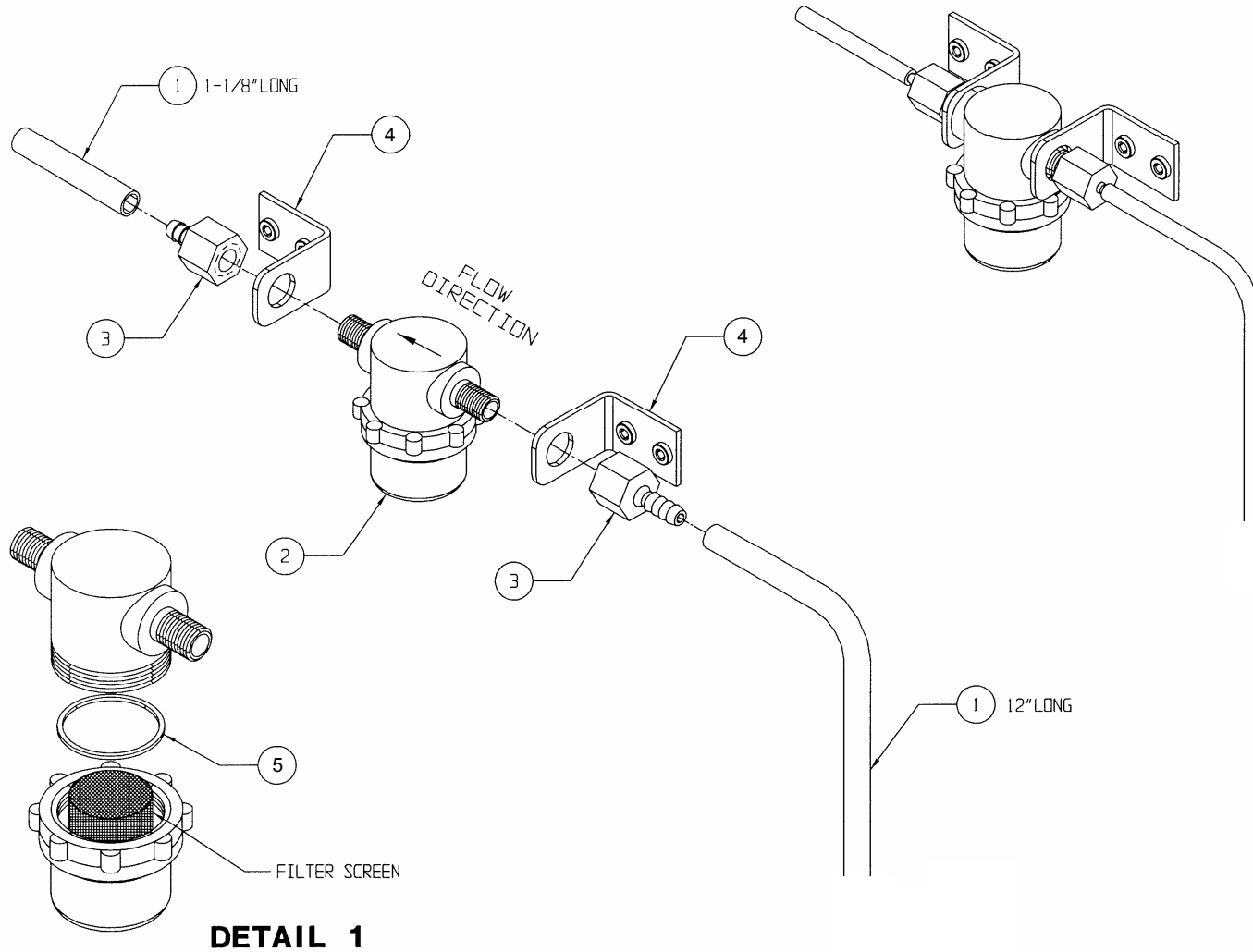



## FILTER MOUNT ASSEMBLY

	PART NO.	DESCRIPTION	QTY
1	04-128	TYGOTHANE TUBE	13-1/8"
2	04-322	FILTER	1
3	04-398	FITTING, 1/4 ID TUBE, 1/4 NPT FEMALE	2
4	A-0975	FILTER MOUNTING BRACKET	2
5	04-453	O-RING, VITON	1

# SA-9032 VAC-HEAD ASSEMBLY

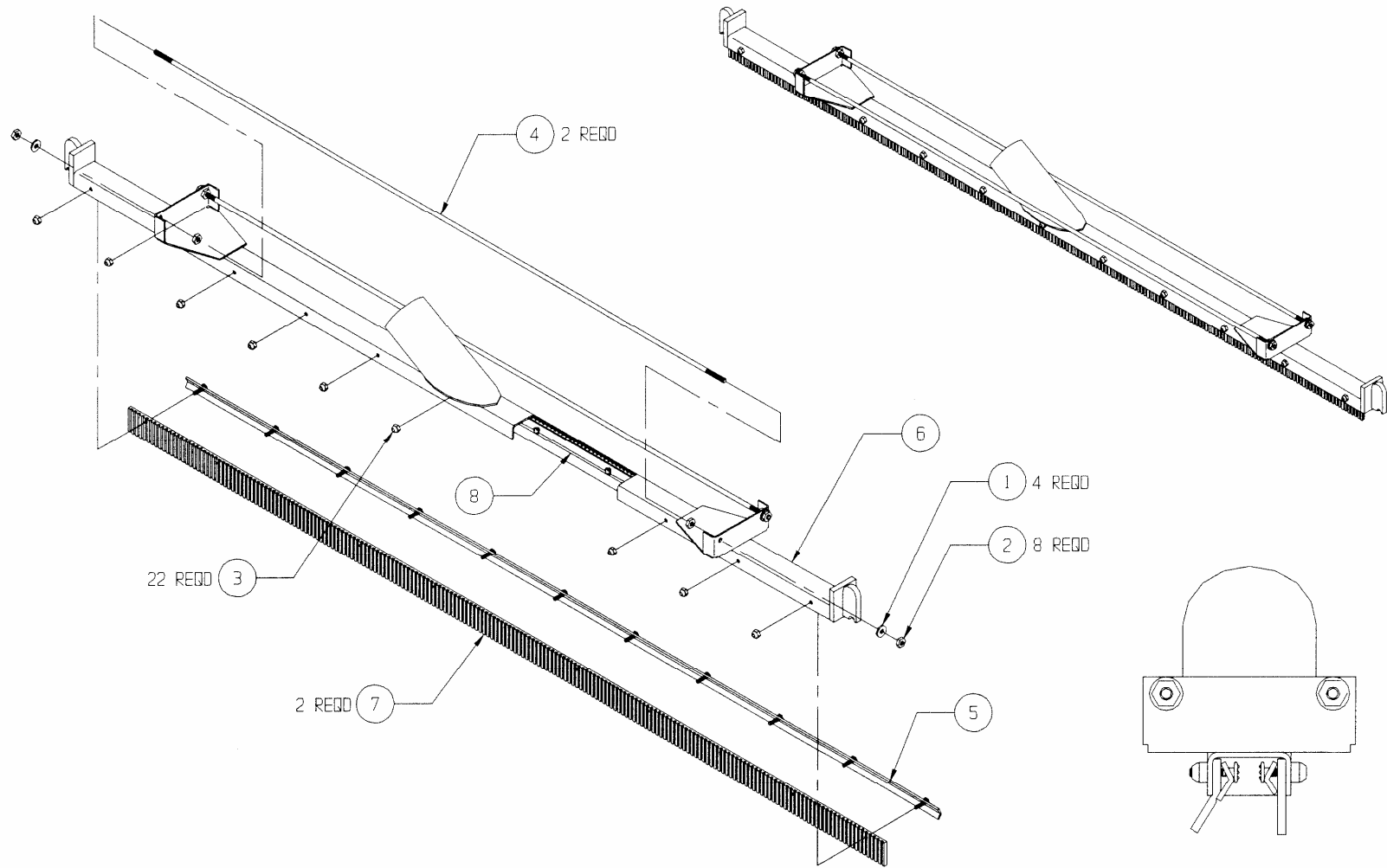

**SA-9032**  
**VAC-HEAD ASSEMBLY**

	<b>PART NO.</b>	<b>DESCRIPTION</b>	<b>QTY</b>
1	01-476	WASHER, #10	4
2	01-032	NUT, 10-32	8
3	01-229	LOCK NUT, 6-32 NYLON INSERT, STAINLESS	22
4	A-8340	VAC-HEAD TENSION ROD	2
5	SA-0283	SQUEEGEE BRACKET WELDMENT, REAR	1
6	SA-9029	VACUUM HEAD WELDMENT	1
7	SV-21	SQUEEGEE	2
8	SV-A4	SQUEEGEE BRACKET WELDMENT, FRONT	1

**SA-0256  
CLEANER PAD ASSEMBLY**

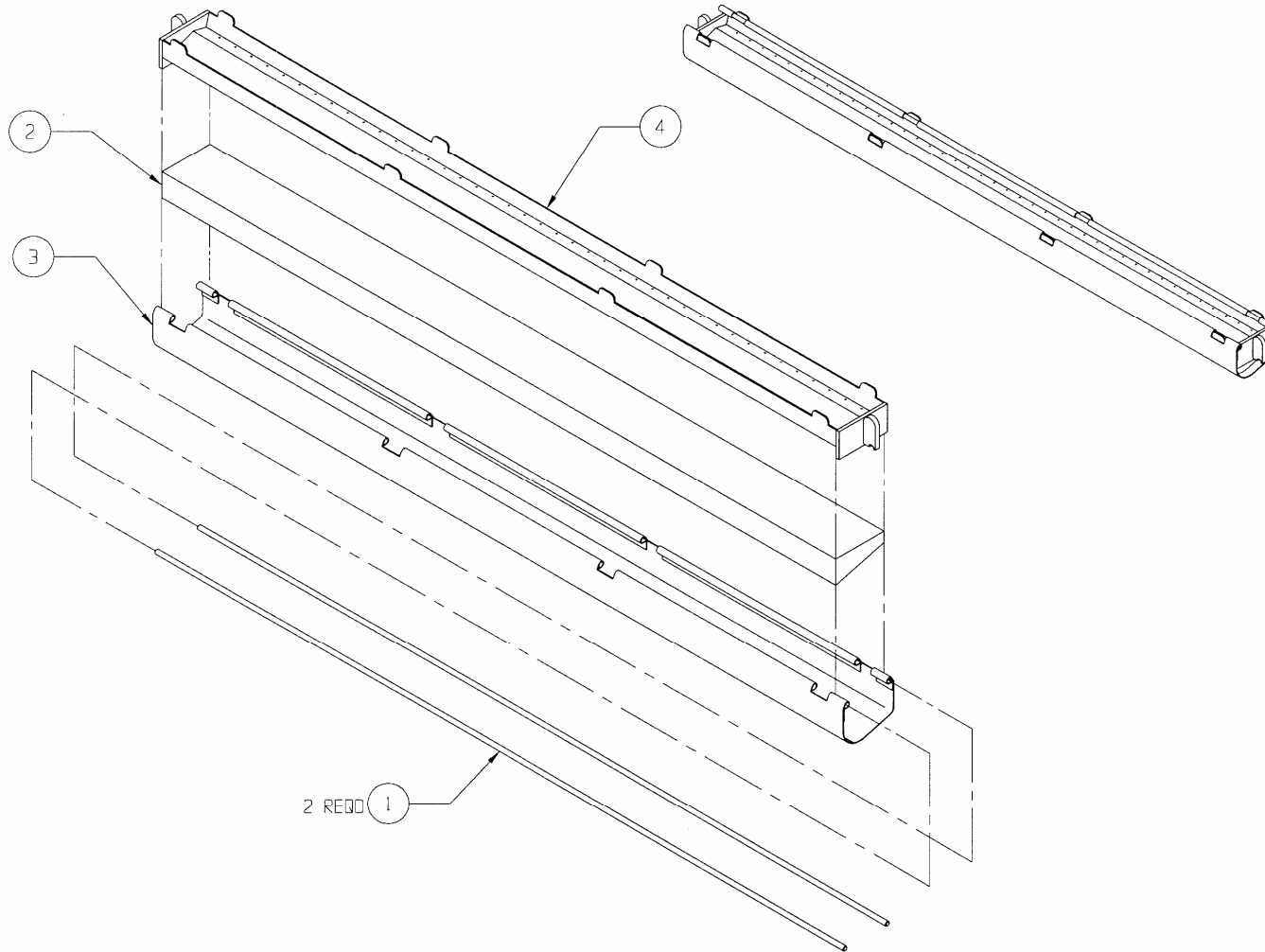

**SA-0256**  
**CLEANER PAD ASSEMBLY**

	<b>PART NO.</b>	<b>DESCRIPTION</b>	<b>QTY</b>
1	A-0784	CLEANING FABRIC SUPPORT ROD	2
2	B-8032	CLEANER PAD	1
3	C-0776	CLEANING FABRIC	1
4	SA-0255	CLEANER TRAY WELDMENT	1

**SA-0321  
VACUUM HEAD SLIDE BLOCK MOUNT ASSEMBLY**

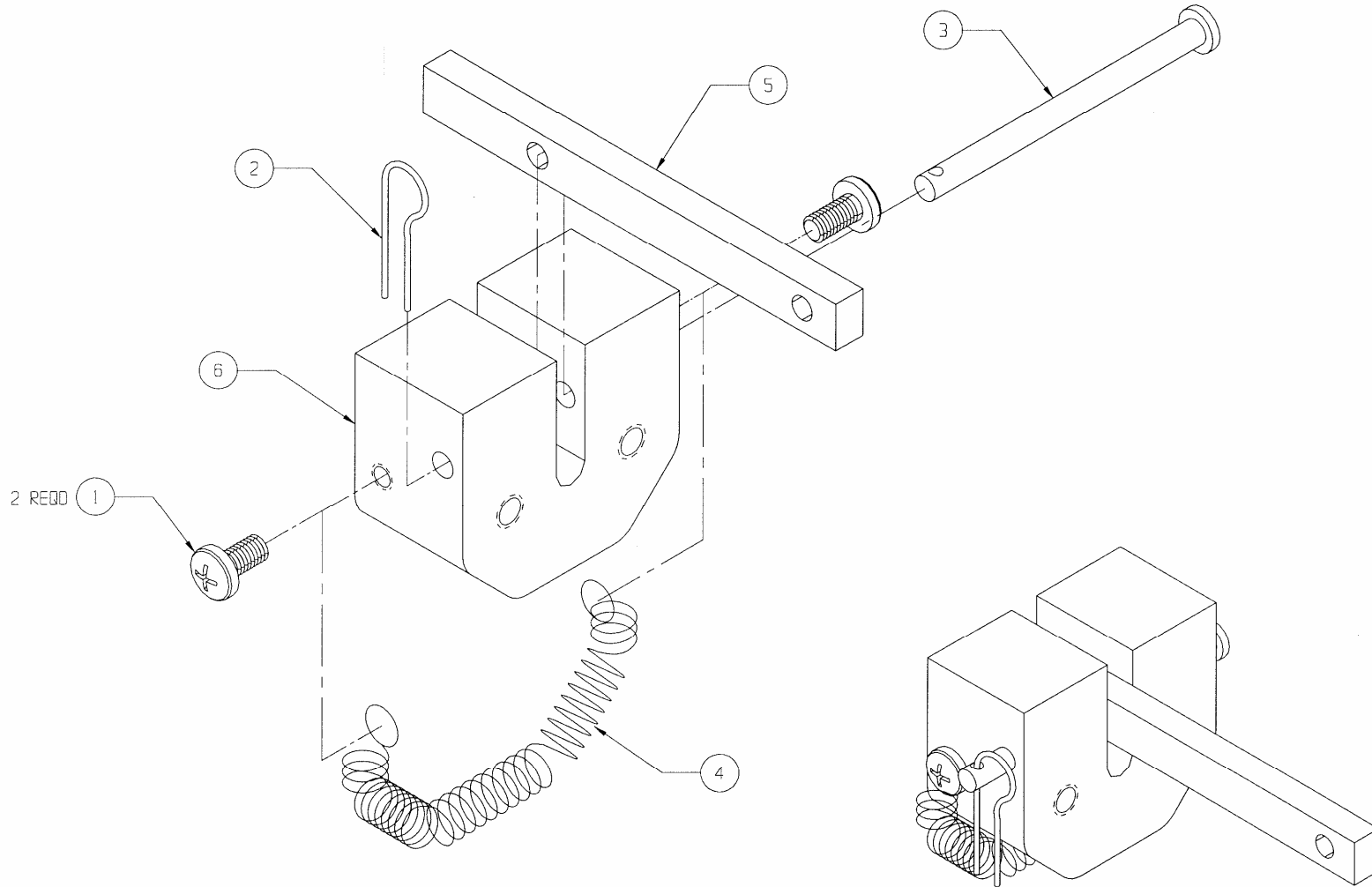

**SA-0321****VACUUM HEAD SLIDE BLOCK MOUNT ASSEMBLY**

	<b>PART NO.</b>	<b>DESCRIPTION</b>	<b>QTY</b>
1	01-019	SCREW, 10-32 X 3/8 PAN HEAD	2
2	01-040	HAIR PIN CLIP, 3/64 X 9/16	1
3	01-162	CLEVIS PIN, 3/16 X 2 1/2	1
4	A-0271	DUSTER SPRING	1
5	A-1055	VACUUM HEAD LINKAGE ARM	1
6	A-8329	SLIDE BLOCK MOUNT	1

**294-002-482  
CLEANER TRAY MOUNT ASSEMBLY, RIGHT**

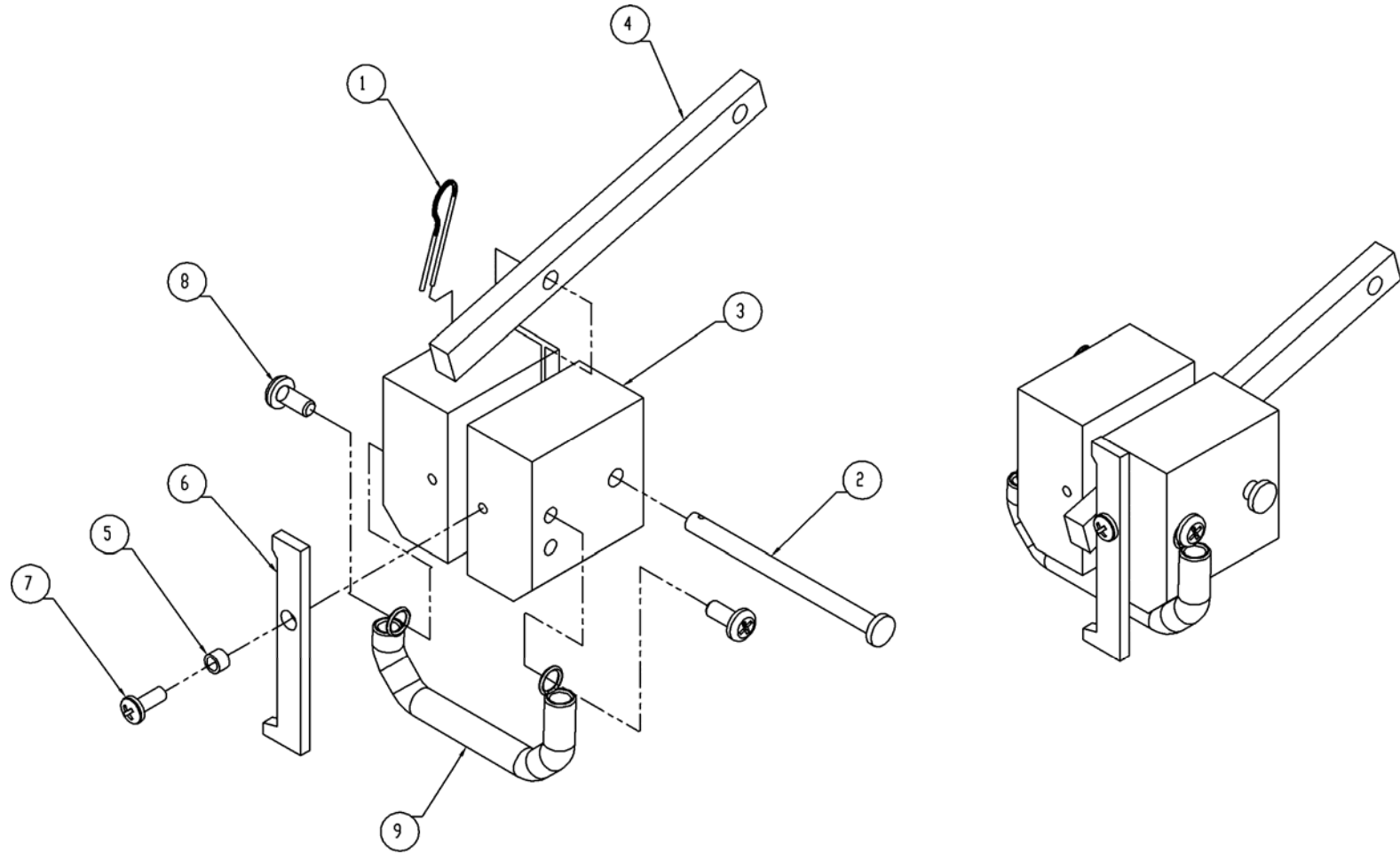



**294-002-482****CLEANER TRAY MOUNT ASSEMBLY, RIGHT**

	<b>PART NO.</b>	<b>DESCRIPTION</b>	<b>QTY</b>
1	01-040	PIN, 3/64 X 9/16, HAIR CLIP, ZINC	1
2	01-162	PIN, 3/16 X 2-1/2, CLEVIS	1
3	294-002-480	SLIDE BLOCK MOUNT, CLEANER TRAY	1
4	A-1056	CLEANER LINKAGE ARM	1
5	A-8284	TRAY LOCK PIVOT	1
6	A-8285	TRAY LOCK	1
7	01-186	SCREW, #6-32 X 3/8, PAN HEAD	1
8	01-019	SCREW, #10-32 X 3/8, PHIL, PAN HEAD, ZINC	2
9	A-0271	DUSTER SPRING	1

**294-002-481  
CLEANER TRAY MOUNT ASSEMBLY, LEFT**

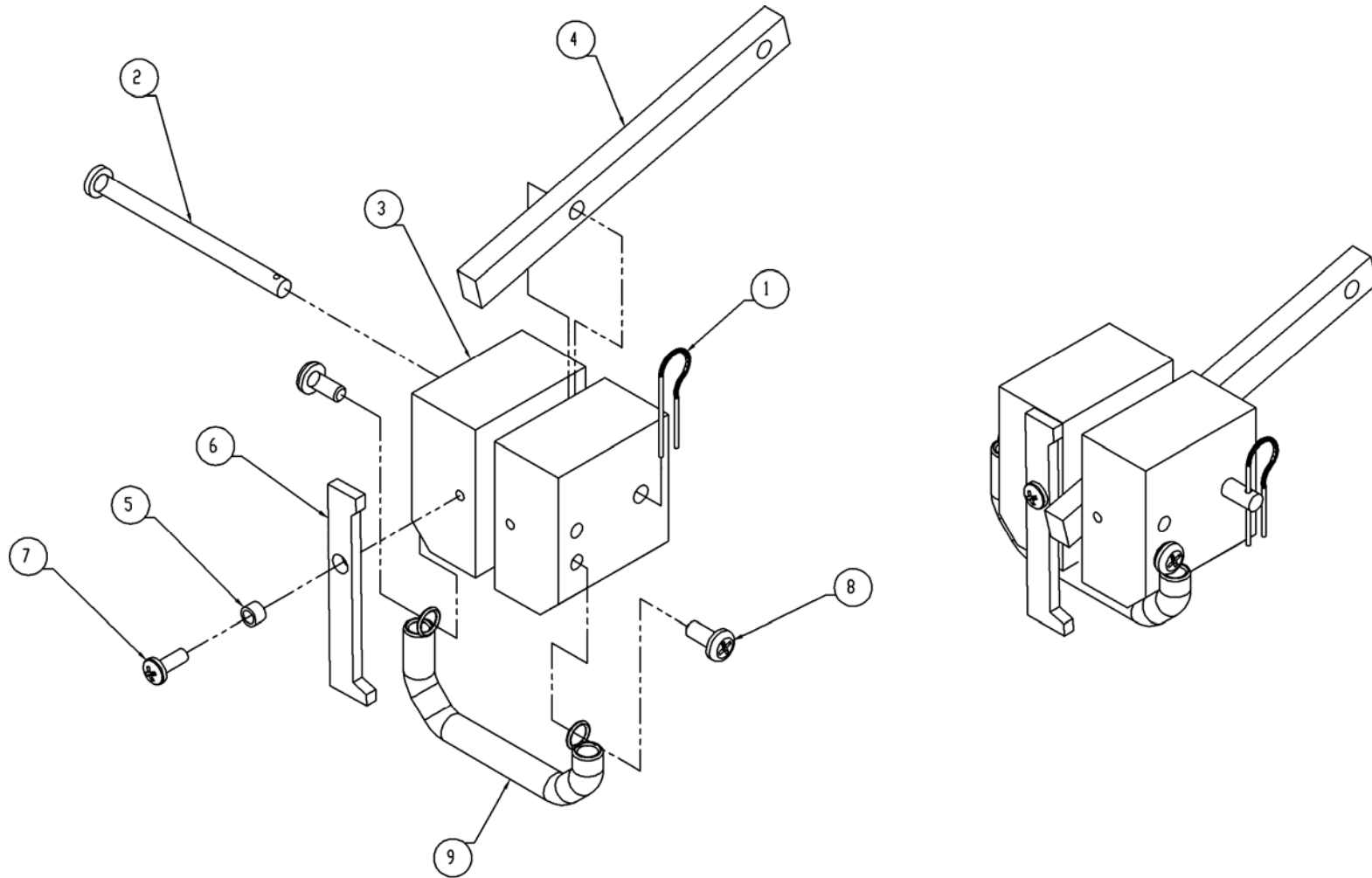

**294-002-481****CLEANER TRAY MOUNT ASSEMBLY, LEFT**

	<b>PART NO.</b>	<b>DESCRIPTION</b>	<b>QTY</b>
1	01-040	PIN, 3/64 X 9/16, HAIR CLIP, ZINC	1
2	01-162	PIN, 3/16 X 2-1/2, CLEVIS	1
3	294-002-480	SLIDE BLOCK MOUNT, CLEANER TRAY	1
4	A-1056	CLEANER LINKAGE ARM	1
5	A-8284	TRAY LOCK PIVOT	1
6	A-8285	TRAY LOCK	1
7	01-186	SCREW, #6-32 X 3/8, PAN HEAD	1
8	01-019	SCREW, #10-32 X 3/8, PHIL, PAN HEAD, ZINC	2
9	A-0271	DUSTER SPRING	1

# SA-1129 WASTE TANK ASSEMBLY

PART NO.	DESCRIPTION
1	C-8341 POLYETHYLENE TANK
2	A-8308 WASTE TANK HANDLE
3	01-148 SCREW: 1/4-20 X 3/4, PHILLIPS, FLAT HEAD, ZINC

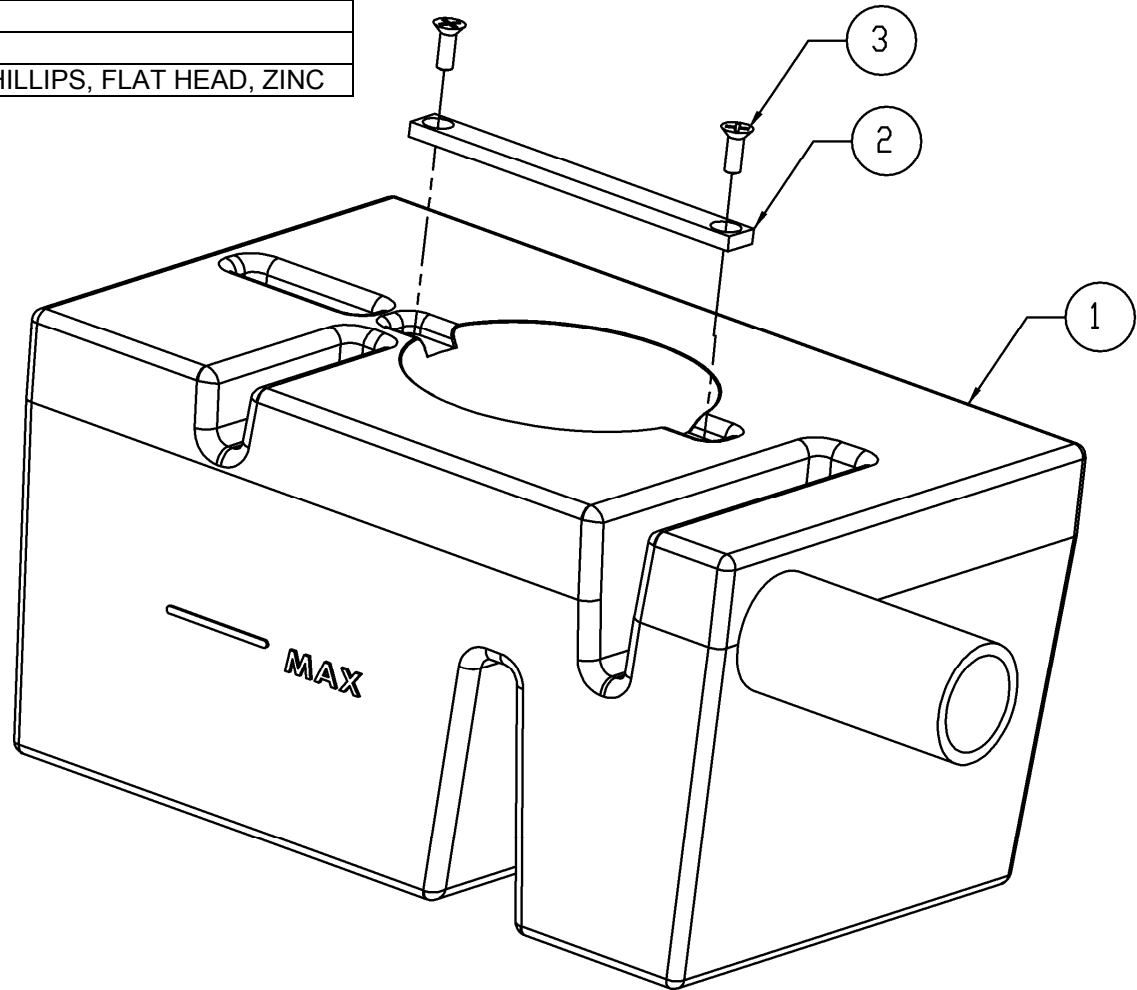

# SA-1101 VACUUM HOSE ASSEMBLY

	PART NO.	DESCRIPTION	QTY
1	04-149	VACUUM HOSE	1
2	04-150	1 1/2 X 2 SLIP ADAPTER	2

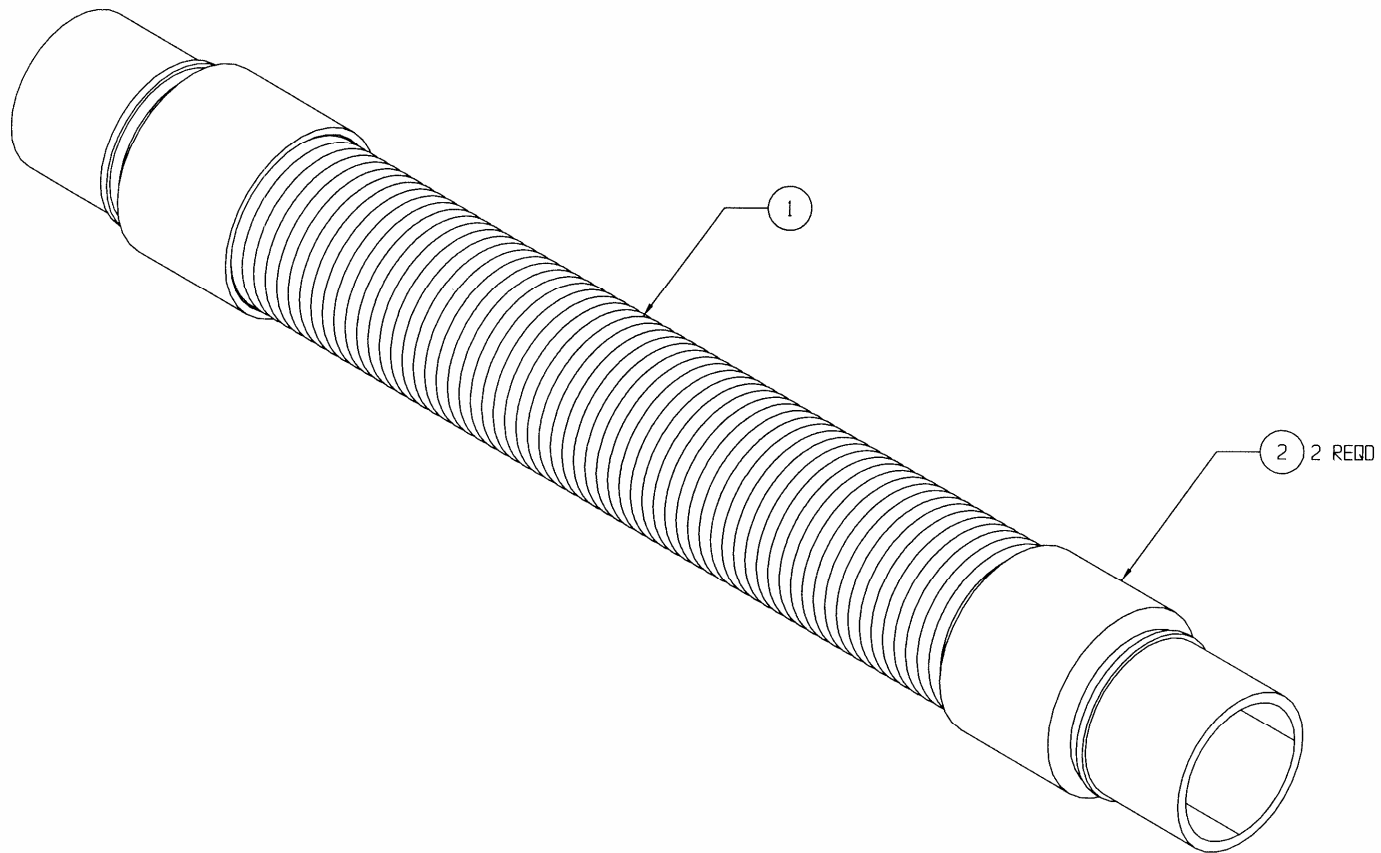

# BASE PLATE ASSEMBLY DRIVE MOTOR, BUFFER MOTOR, DRIVE SHAFT

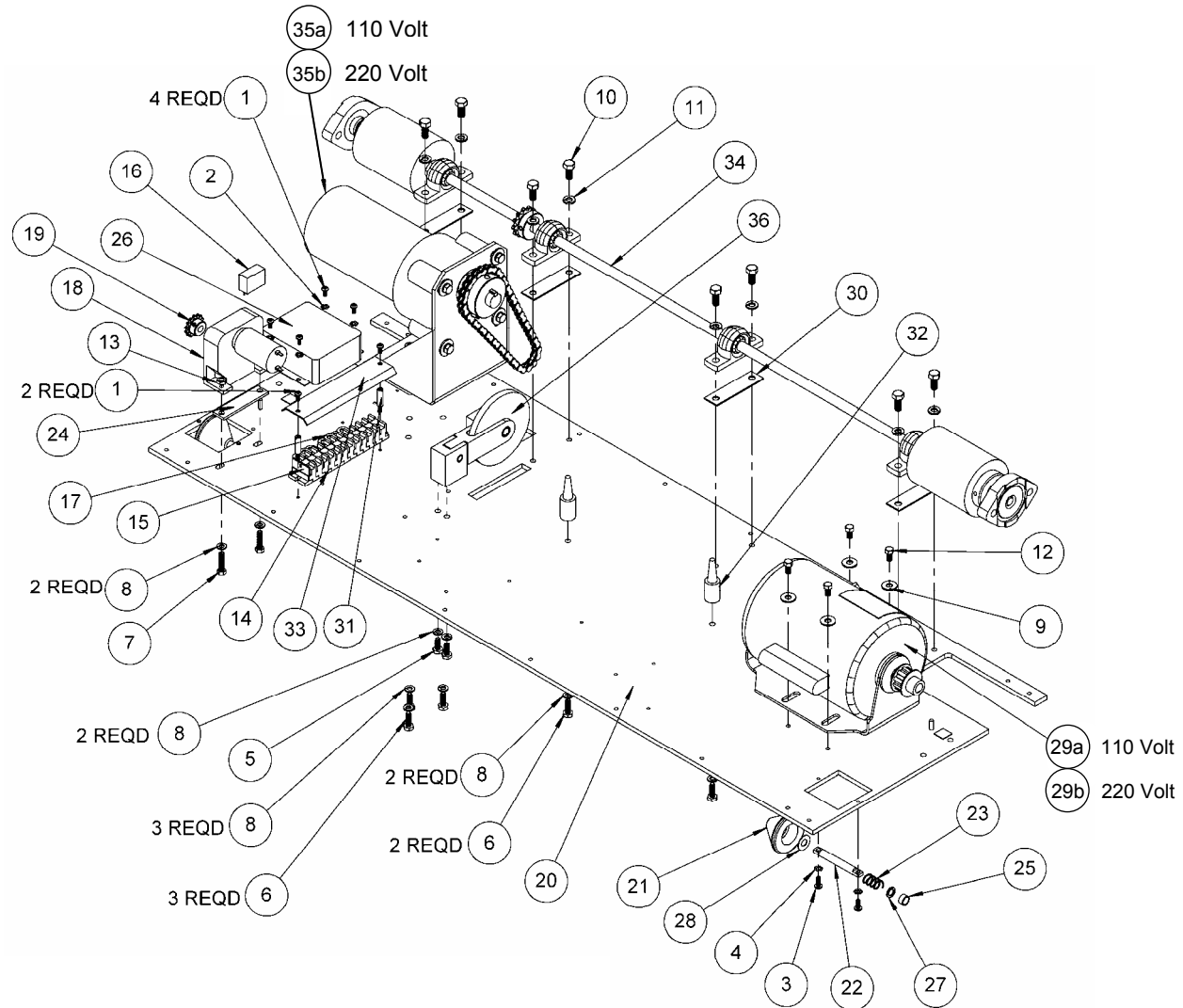

## BASE PLATE ASSEMBLY DRIVE MOTOR, BUFFER MOTOR, DRIVE SHAFT

	PART NO.	DESCRIPTION	QTY
1	01-009	SCREW, 8-32 X 3/8 PAN HEAD	6
2	01-016	LOCK WASHER, #8 EXTERNAL TOOTH	4
3	01-021	SCREW, 10-32 X 1/2 PAN HEAD	4
4	01-033	LOCK WASHER, #10 EXTERNAL TOOTH	4
5	01-044	SCREW, 1/4-20 X 5/8 HEX HEAD	2
6	01-046	SCREW, 1/4-20 X 3/4 HEX HEAD	5
7	01-048	SCREW, 1/4-20 X 1 HEX HEAD	2
8	01-054	LOCK WASHER, 1/4 SPLIT	9
9	01-056	FLAT WASHER, 1/4 USS	4
10	01-059	SCREW, 5/16-18 X 3/4 HEX HEAD	8
11	01-063	LOCK WASHER, 5/16 SPLIT	8
12	01-115	SCREW, 1/4-20 X 1/2 HEX HEAD	4
13	835-549-002	NUT, 1/4-20 THIN	2
14	02-015	TERMINAL BLOCK SECTION	12
15	02-016	TERMINAL BLOCK END SECTION	1
16	02-038	CAPACITOR, 1.0 $\mu$ f, 250V (in 220V only)	1
17	02-078	TERMINAL BLOCK JUMPER	7
18	02-767	TRANSFER ROLLER MOTOR	1
19	294-001-006	SPROCKET, #25, 14 TOOTH, 3/8 BORE	1

	PART NO.	DESCRIPTION	QTY
20	294-002-428	BASE PLATE	1
21	294-002-011	GUIDE ROLLER ASSEMBLY	2
22	294-002-016	GUIDE ROLLER SHAFT	2
23	294-002-025	GUIDE SPRING	2
24	294-002-082	TRANSFER ROLLER MOTOR SPACER	1
25	294-002-087	GUIDE SHAFT SPACER	2
26	294-002-120	30-VK6 RFI POWER LINE FILTER (in 220V only)	1
27	945-546-900	GUIDE ROLLER WASHER	2
28	964-572-000	THRUST WASHER	2
29a	294-002-350*	BUFFER MOTOR ASSEMBLY, 110 VOLT	1
29b	294-002-270	BUFFER MOTOR ASSEMBLY, 220 VOLT	1
30	A-0073	PILLOW BLOCK SHIM	4
31	A-0468	TERMINAL BLOCK COVER SPACER	2
32	A-8331	TANK LOCATING PIN	2
33	SA-0033B	TERMINAL BLOCK COVER ASSEMBLY	1
34	SA-0279*	DRIVE SHAFT ASSEMBLY	1
35a	SA-0259*	DRIVE MOTOR ASSEMBLY, 110 VOLT	1
35b	SA-0291*	DRIVE MOTOR ASSEMBLY, 220 VOLT	1
36	SA-1205*	COUNTER WHEEL ASSEMBLY	1

\* For more information, refer to the individual part drawing.

**SA-0259 (110 VOLT)  
SA-0291 (220 VOLT)  
DRIVE MOTOR ASSEMBLY**

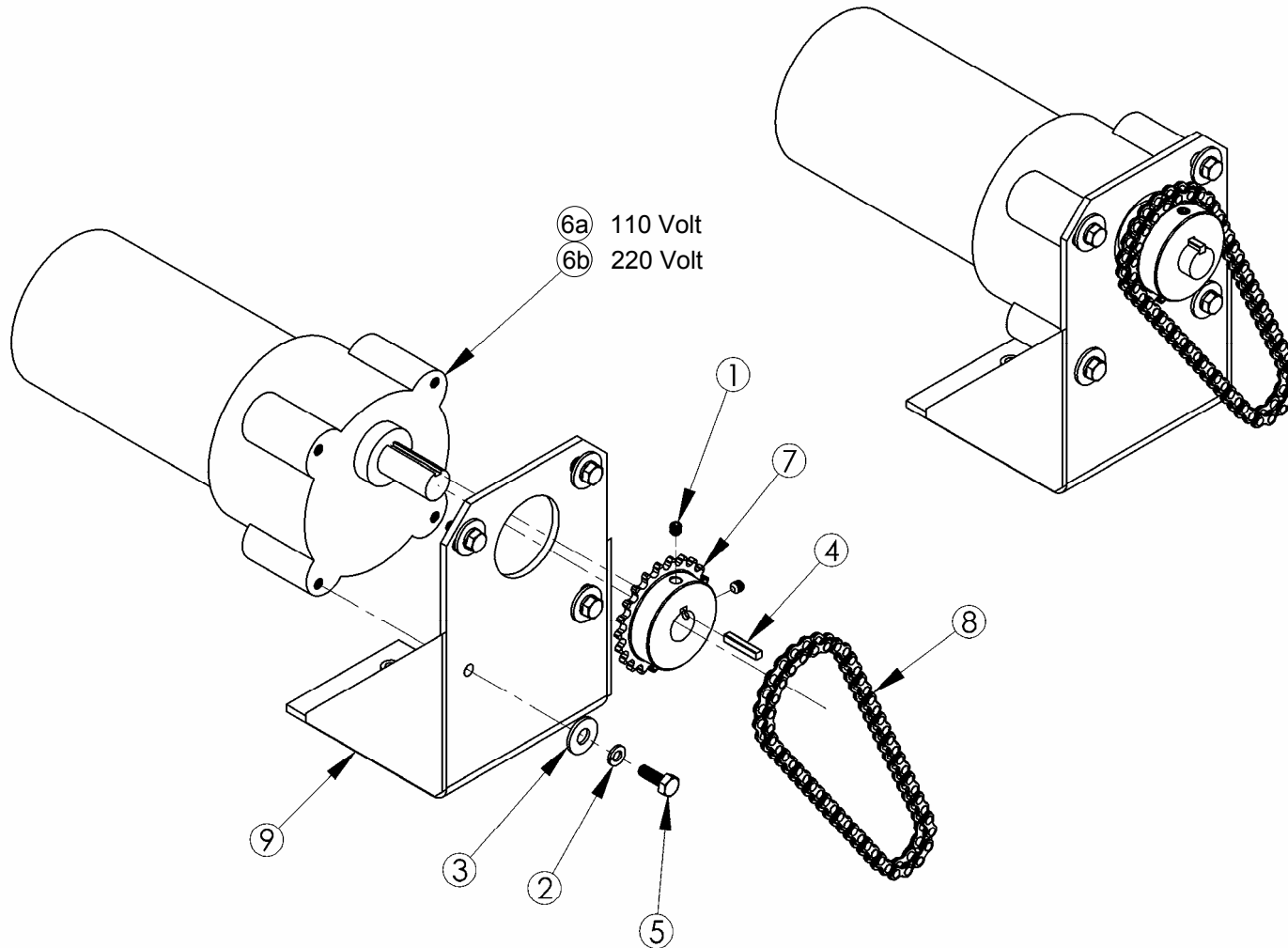



**SA-0259 (110 VOLT)  
SA-0291 (220 VOLT)  
DRIVE MOTOR ASSEMBLY**

	<b>PART NO.</b>	<b>DESCRIPTION</b>	<b>QTY</b>
1	01-041	SET SCREW, 1/4-20 X 1/4 HEX SOCKET HEAD, CUP POINT	2
2	951-148-002	LOCK WASHER, 1/4 SPLIT	4
3	01-065	FLAT WASHER, 5/16 USS	4
4	01-352	KEY, 3/16 X 3/16 X 1"	1
5	01-569	SCREW, 1/4-28 X 3/4 HEX HEAD	4
6a	02-770	MOTOR, DRIVE, 90 VDC	1
6b	02-786	MOTOR, DRIVE, 180 VDC	1
7	03-108	SPROCKET, #35 CHAIN, 22 TOOTH, 3/4 BORE	1
8	A-0855	CHAIN, #35, 17-5/8 LENGTH	1
9	SA-0257	DRIVE MOTOR BRACKET WELDMENT	1

# SA-0279 DRIVE SHAFT ASSEMBLY

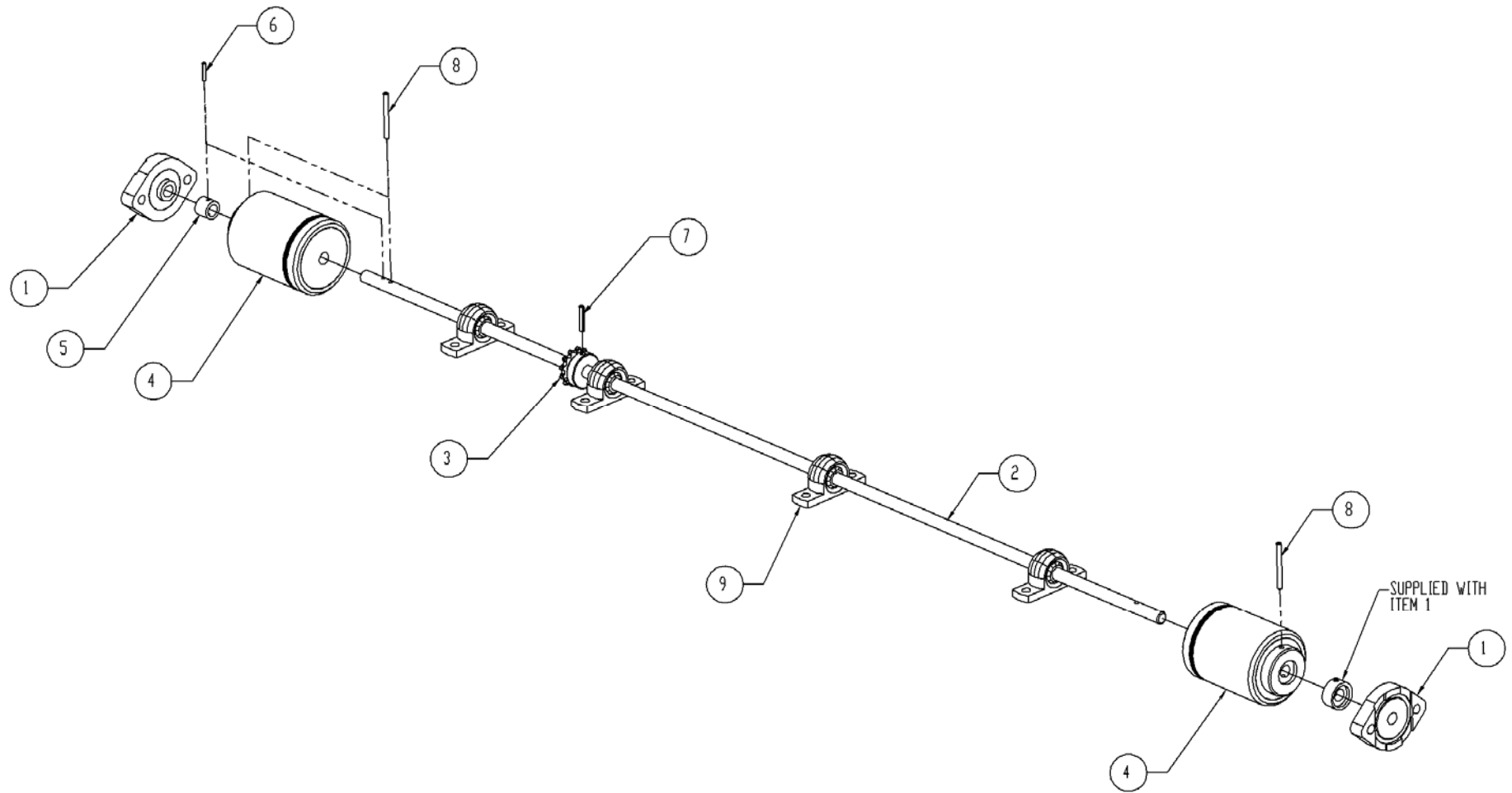

**SA-0279****DRIVE SHAFT ASSEMBLY**

	<b>PART NO.</b>	<b>DESCRIPTION</b>	<b>QTY</b>
1	A-0041	BEARING MODIFICATION-DRIVE SHAFT END	2
2	A-0337	DRIVE SHAFT	1
3	A-0521	DRIVE SHAFT SPROCKET MODIFICATION	1
4	294-115-404	DRIVE WHEEL	2
5	A-8011	DRIVE SHAFT SPACER	1
6	01-078	ROLL PIN, 1/8 X 3/4	1
7	01-082	ROLL PIN, 3/16 X 1-1/8	1
8	01-087	ROLL PIN, 3/16 X 2	2
9	03-004	PILLOW BLOCK	4

# SA-1205 COUNTER WHEEL ASSEMBLY

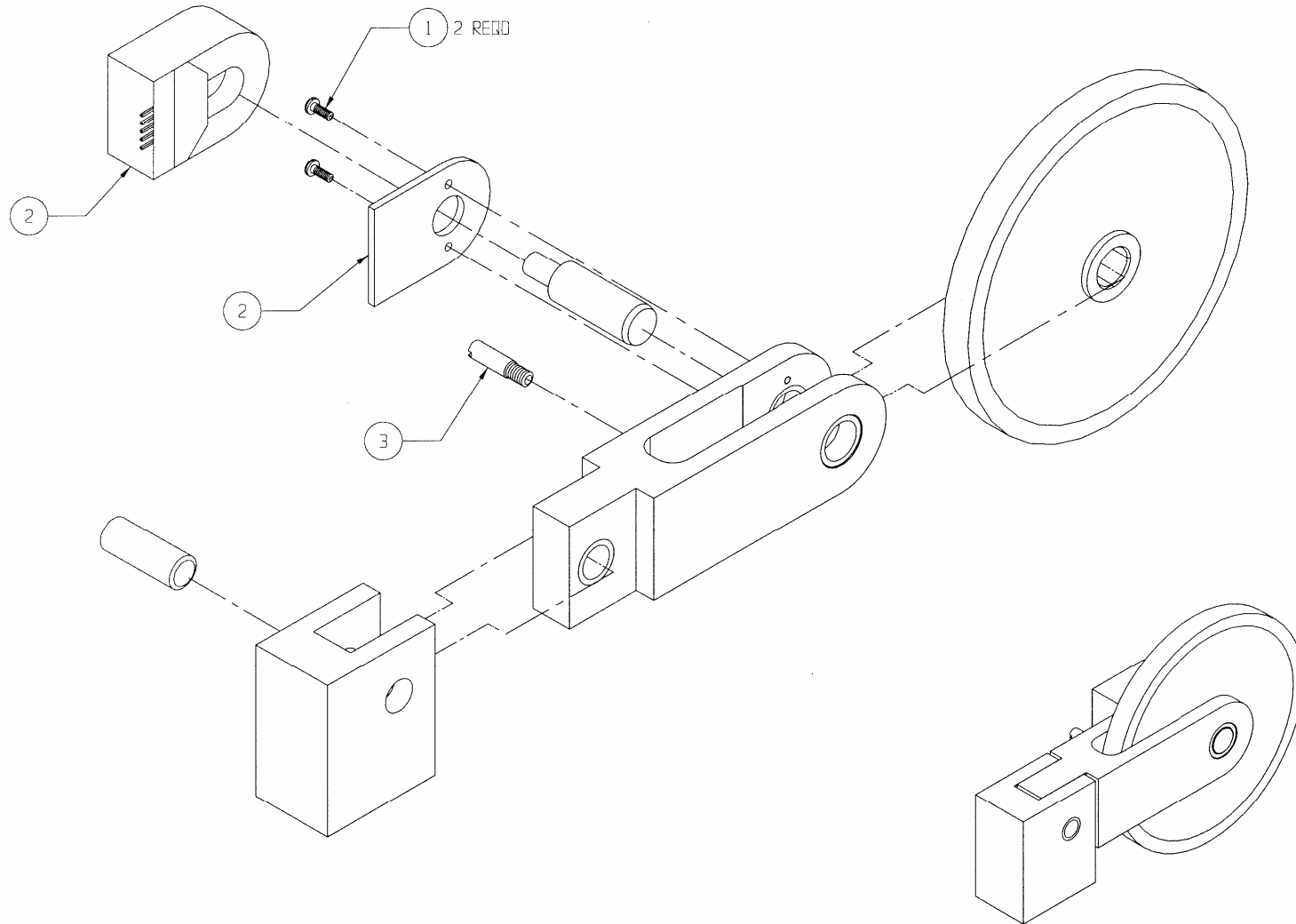

**SA-1205  
COUNTER WHEEL ASSEMBLY**

	<b>PART NO.</b>	<b>DESCRIPTION</b>	<b>QTY</b>
1	01-298	SCREW, 2-56 X 1/4 PAN HEAD	2
2	02-309	ENCODER	1
3	A-8249	SHUT OFF ARM STOP	1

# BASE PLATE ASSEMBLY CONTROL BOX, SPEED CONTROL BOX, DASH

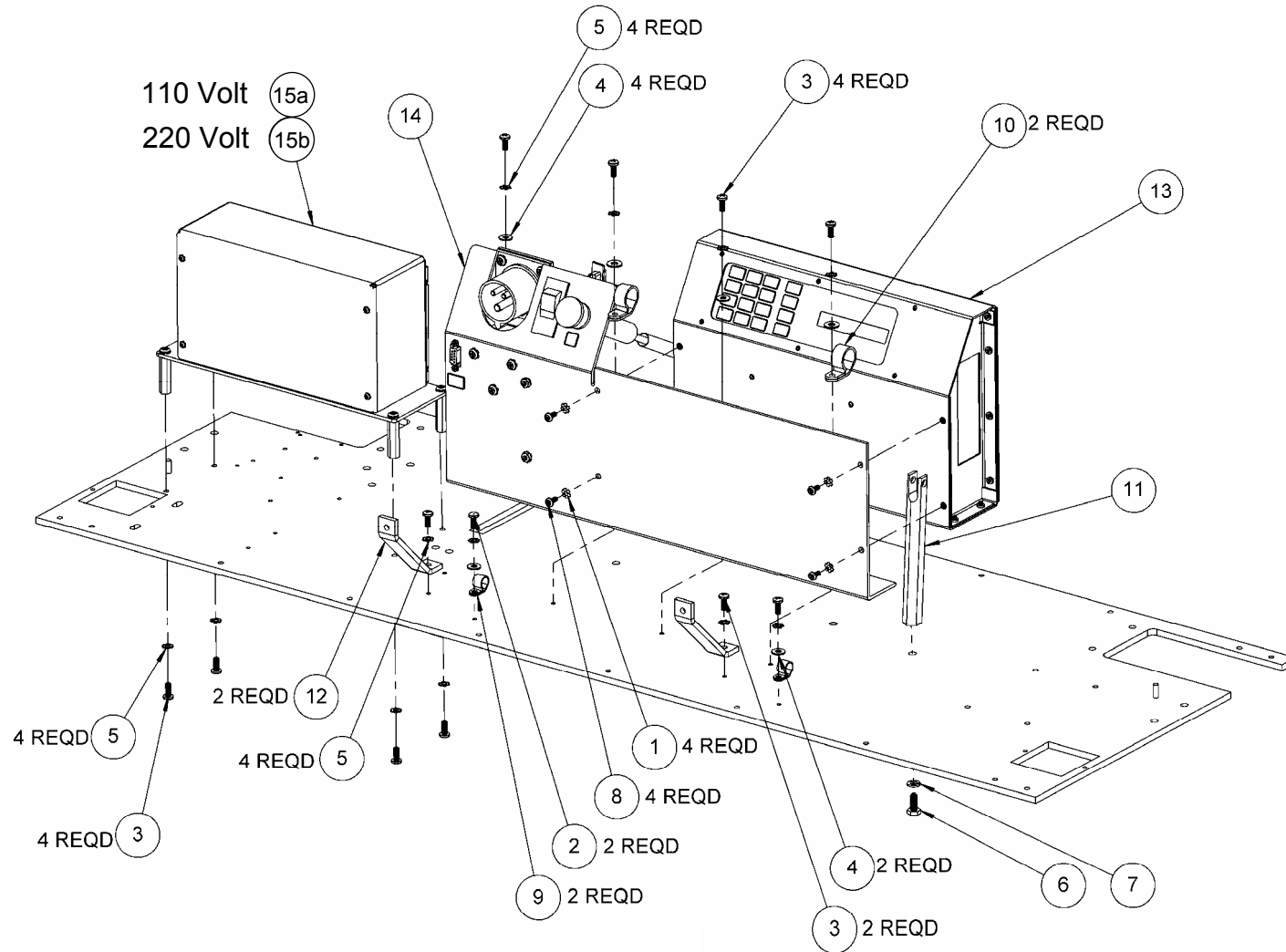

**BASE PLATE ASSEMBLY  
CONTROL BOX, SPEED CONTROL BOX, DASH**

	<b>PART NO.</b>	<b>DESCRIPTION</b>	<b>QTY</b>
1	01-016	LOCK WASHER, #8 EXTERNAL TOOTH	4
2	01-019	SCREW, 10-32 X 3/8 PAN HEAD	2
3	01-021	SCREW, 10-32 X 1/2 PAN HEAD	10
4	01-030	FLAT WASHER, #10 USS	6
5	01-033	LOCK WASHER, #10 EXTERNAL TOOTH	12
6	01-044	SCREW, 1/4-20 X 5/8 HEX HEAD	1
7	01-054	LOCK WASHER, 1/4 SPLIT	1
8	01-302	SCREW, 8-32 X 3/8 HEX HEAD	4
9	02-013	WIRE CLAMP, PLASTIC	2
10	02-086	WIRE CLAMP, PLASTIC	2
11	294-002-003	VERTICAL VACUUM MOTOR MOUNT	1
12	294-002-078	FIREWALL SUPPORT BRACKET	2
13	294-002-505	CONTROL BOX ASSEMBLY	1
14	294-002-421*	DASH ASSEMBLY	1
15a	SA-0250	SPEED CONTROL BOX ASSEMBLY (110 Volt)	1
15b	SA-0260	SPEED CONTROL BOX ASSEMBLY (220 Volt)	1

\* For more information, refer to the individual part drawing.

**294-002-421  
DASH ASSEMBLY**

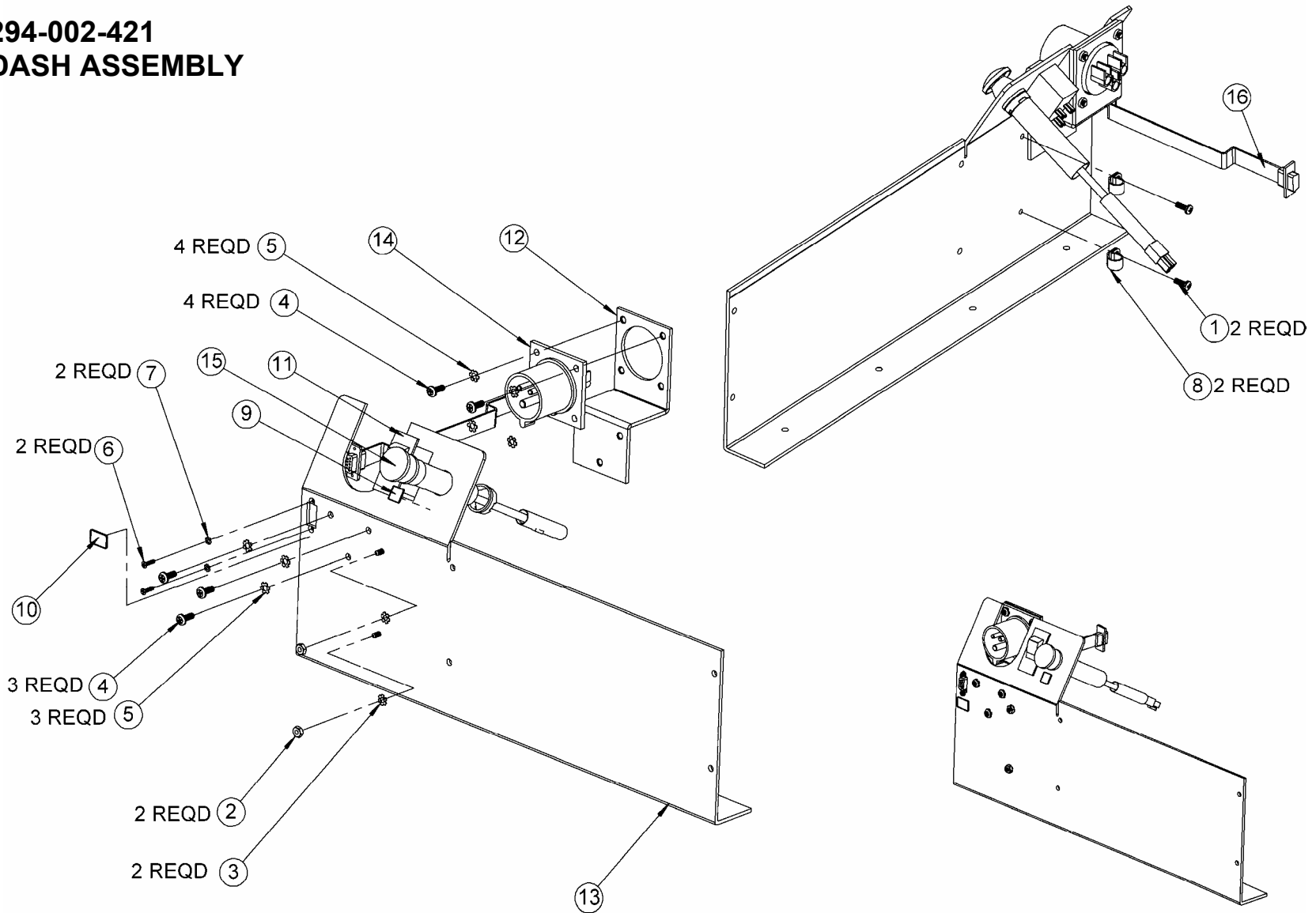



**294-002-421**  
**DASH ASSEMBLY**

	<b>PART NO.</b>	<b>DESCRIPTION</b>	<b>QTY</b>
1	01-010	SCREW, 8-32 X 1/2 PAN HEAD	2
2	01-015	NUT, 8-32	2
3	01-016	LOCK WASHER, #8 EXTERNAL TOOTH	2
4	01-021	SCREW, 10-32 X 1/2 PAN HEAD	7
5	01-033	LOCK WASHER, #10 EXTERNAL TOOTH	7
6	01-178	SCREW, 4-40 X 3/8 FLAT HEAD	2
7	01-618	LOCK WASHER, #4 EXTERNAL TOOTH COUNTERSUNK	2
8	02-013	WIRE CLAMP, PLASTIC	2
9	294-002-183	LABEL, MANUAL REVERSE SYMBOL	1
10	294-002-185	LABEL, COM-PORT SYMBOL	1
11	294-002-214	CIRCUIT BREAKER	1
12	294-002-215	DASH CONNECTOR SUPPORT	1
13	294-002-440	DASH PLATE	1
14	294-002-218	PANEL MOUNT POWER INLET	1
15	294-002-279	MANUAL REVERSE SWITCH ASSEMBLY	1
16	SA-0282	PROGRAMMING CABLE, DASH TO CONTROL BOX	1

**294-002-238  
FUSE BLOCK ASSEMBLY**

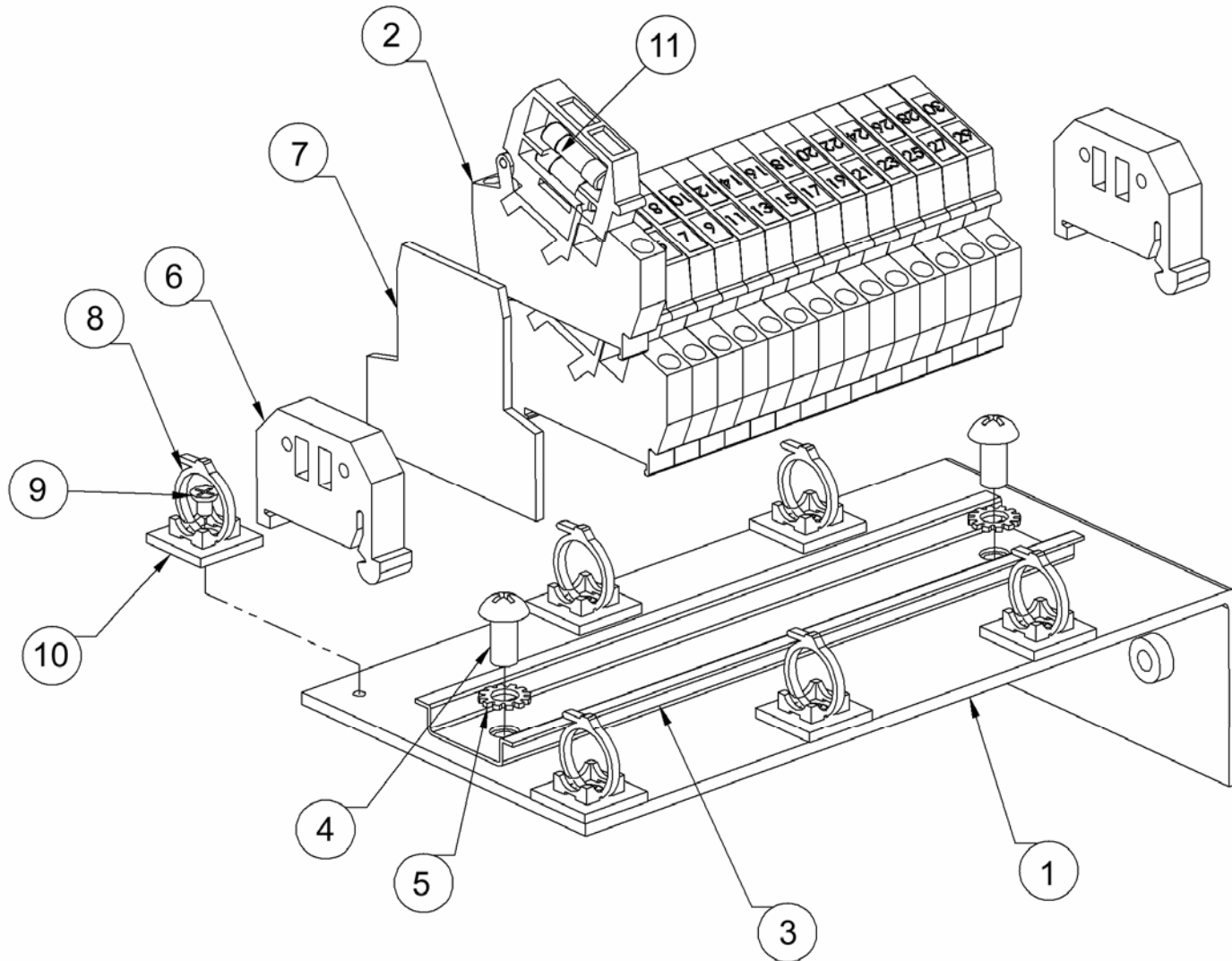

**294-002-238**  
**FUSE BLOCK ASSEMBLY**

	<b>PART NO.</b>	<b>DESCRIPTION</b>	<b>QTY</b>
1	294-002-226	FUSE MOUNTING BRACKET	1
2	294-002-241	FUSED DISCONNECT TERMINAL BLOCK, PIVOTABLE	15
3	294-002-237	DIN-RAIL MOUNT	1
4	01-027	SCREW, 1/4-20 X 1/2 ROUND HEAD	2
5	01-053	LOCK WASHER, 1/4 EXTERNAL TOOTH	2
6	294-002-232	END STOP, SCREWLESS	2
7	294-002-240	END PLATE	1
8	770-013-043	PANDUIT STRAP	6
9	01-355	SCREW, 6 X 1/4 FLAT HEAD, PHILLIPS	6
10	02-539	ADHESIVE WIRE MOUNT	6
11	See Below	FUSE, 5 x 20 MM	-

**Fuses for 110 Volt S Series**

294-002-327	FUSE, 5 x 20 MM, T 1.00A	1
294-002-324	FUSE, 5 x 20 MM, T 4.00A	12
294-002-325	FUSE, 5 x 20 MM, T 6.30A	1
294-002-326	FUSE, 5 x 20 MM, T 10.00A	1

**Fuses for 220 Volt S Series**

294-002-246	FUSE, 5 x 20 MM, T 500MA	1
294-002-252	FUSE, 5 x 20 MM, T 2.00A	12
294-002-253	FUSE, 5 x 20 MM, T 3.15A	1
294-002-254	FUSE, 5 x 20 MM, T 5.00A	1

**SA-1049 SHUT OFF ARM ASSEMBLY**  
**SA-1186 SPRING AND CAP ASSEMBLY**

	<b>PART NO.</b>	<b>DESCRIPTION</b>	<b>QTY</b>
1	B-0111	SHUT OFF ARM SHAFT	1
2	SA-1049	SHUT OFF ARM ASSEMBLY	1
3	SA-1186	SPRING AND CAP ASSEMBLY	1

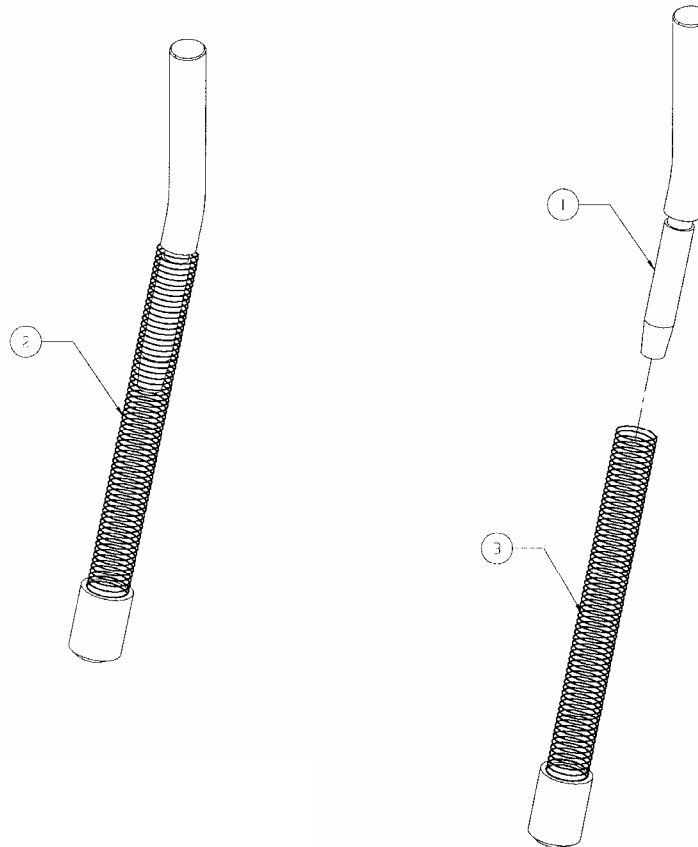

**294-002-419**  
**CENTERING GUIDE PLATE ASSEMBLY**

	<b>PART NO.</b>	<b>DESCRIPTION</b>	<b>QTY</b>
1	01-036	FLAT WASHER, 3/16 USS	2
2	01-052	NUT, 1/4-20	1
3	01-093	SCREW, 1/4-20 X 1 1/2 ROUND HEAD	1
4	04-004	CASTER WHEEL	1
5	294-002-439	CENTERING GUIDE PLATE	1

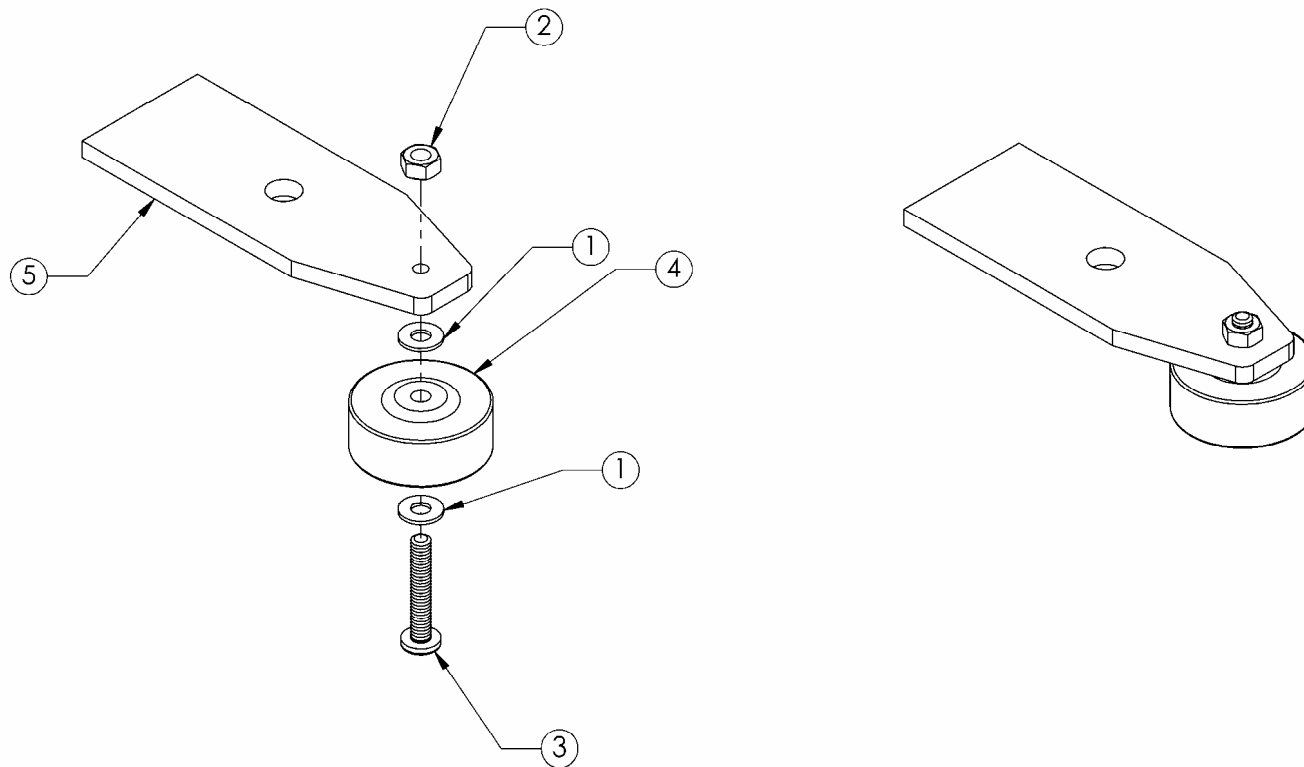

**294-002-136  
TRIP ARM ASSEMBLY**

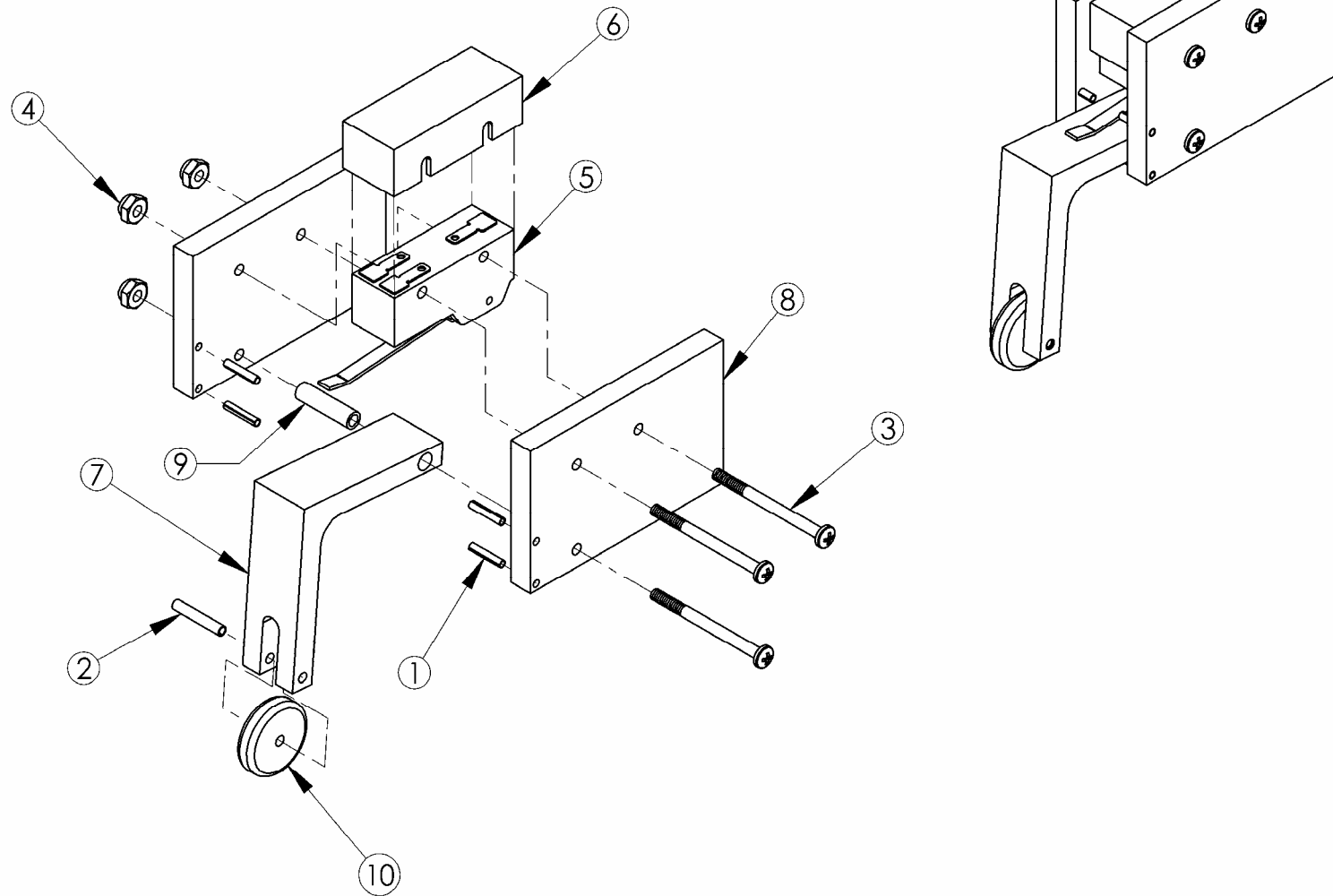

**294-002-136**  
**TRIP ARM ASSEMBLY**

	<b>PART NO.</b>	<b>DESCRIPTION</b>	<b>QTY</b>
1	01-077	ROLL PIN, 3/32 X 1/2	4
2	01-078	ROLL PIN, 1/8 X 3/4	1
3	01-195	SCREW, 6-32 X 1 3/4 ROUND HEAD	3
4	01-416	LOCK NUT, 6-32 NYLON INSERT	3
5	02-023	SWITCH	1
6	02-067	PLASTIC ENCLOSURE	1
7	294-002-134	TRIP ARM	1
8	A-0353	TRIP ARM MOUNT	2
9	A-0355	TRIP ARM SPACER	1
10	A-0356	TRIP ARM WHEEL	1

# FINAL ASSEMBLY

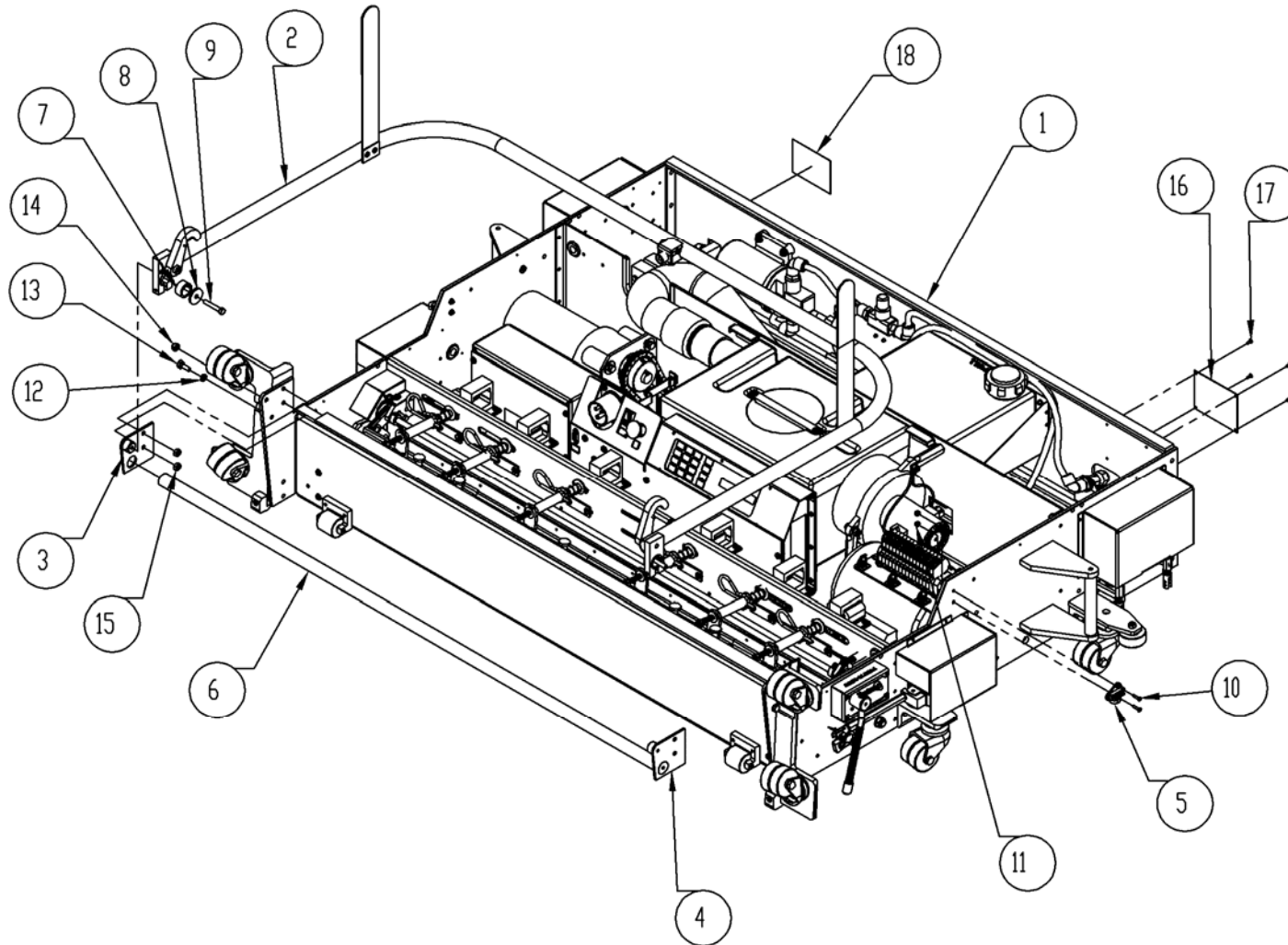



## FINAL ASSEMBLY

	PART NO.	DESCRIPTION	QTY
1	294-002-417	BODY ASSEMBLY, 110 VOLT	1
2	294-002-416	HANDLE ASSEMBLY	1
3	294-002-028	HANDLE PIVOT, LEFT	1
4	294-002-029	HANDLE PIVOT, RIGHT	1
5	A-2037	POWER CABLE HOOK	2
6	B-5012	REAR HANDLE	1
7	A-0453	HANDLE PIVOT BUSHING	2
8	A-0444	HANDLE PIVOT WASHER	2
9	01-253	SCREW, 1/2-20 X 1 1/2, HEX HEAD, ZINC	2
10	812-027-100	SCREW, 6-32 X 5/8 FLAT HEAD	4
11	01-416	NUT, #6-32, NYLON LOCK, ZINC	4
12	01-054	WASHER, 1/4, SPLIT, ZINC	2
13	01-046	SCREW, 1/4-20 X 3/4, HEX HEAD, ZINC	2
14	01-051	NUT, 1/4-20, NYLON LOCK, ZINC	2
15	01-052	NUT, 1/4-20, HEX, ZINC	4
16	A-0580	SERIAL NUMBER PLATE	1
17	01-089	RIVET, 1/8 X 1/4, AL	4
18	A-5574	DECAL - USA FLAG	1

**294-002-416  
HANDLE ASSEMBLY**

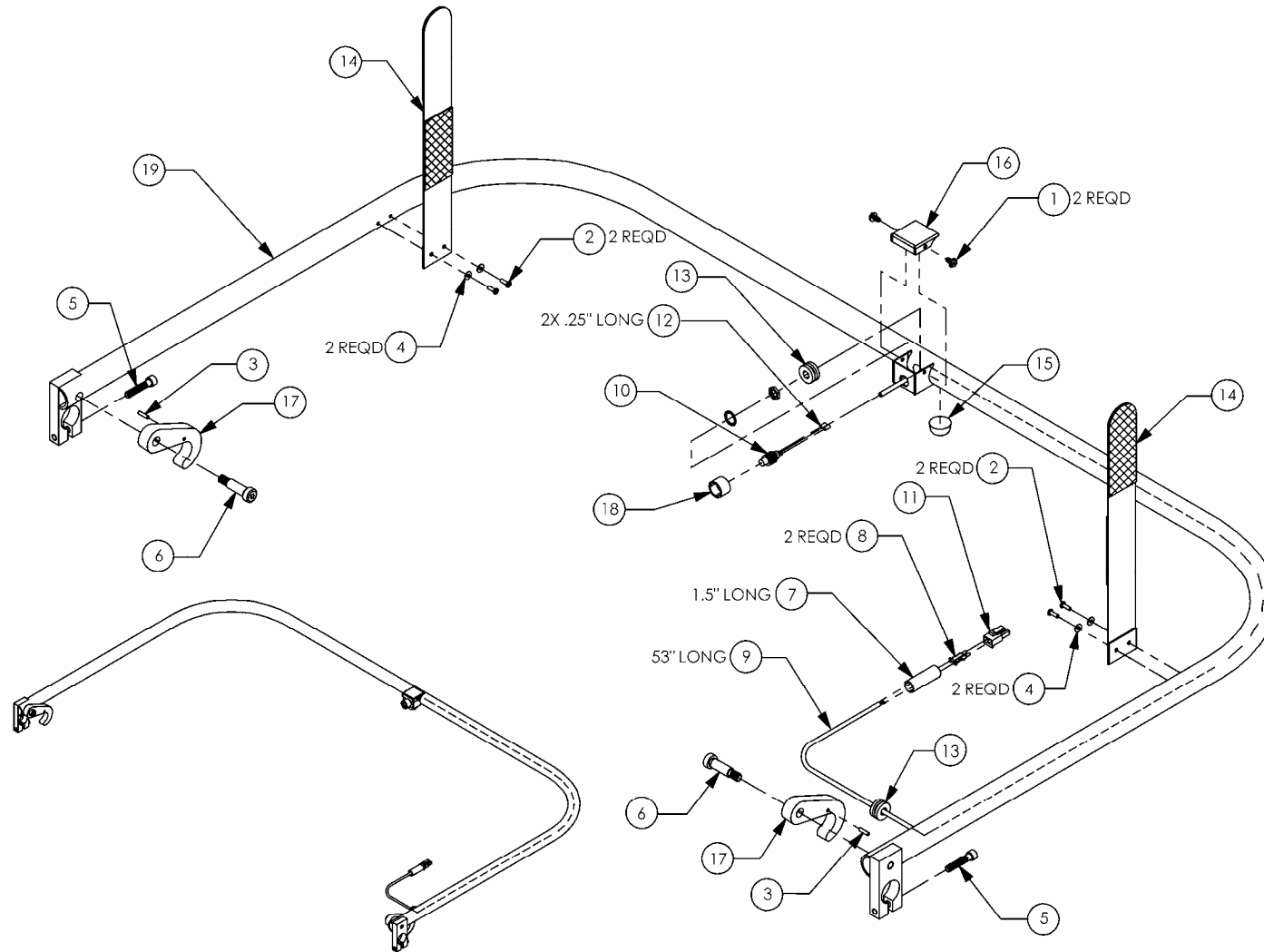

**294-002-416**  
**HANDLE ASSEMBLY**

	<b>PART NO.</b>	<b>DESCRIPTION</b>	<b>QTY</b>
1	01-058	SCREW, #8 X 3/ 8 WASHER-HEAD SELF-TAPPING	2
2	01-130	POP RIVET, 1/8 X 1/2, ALUMINUM	4
3	01-152	ROLL PIN, 1/8 X 1/2	2
4	01-303	FLAT WASHER	4
5	810-349-200	CAP SCREW, 1/4-20 X 1 1/4 HEX SOCKET HEAD, w/NYLON PELLET	2
6	01-310	BOLT, 1/4-20 X 1-1/4, HEX SOCKET	2
7	02-208	HEAT SHRINK TUBE, 1/2 ID	1.5"
8	02-299	CRIMP TERMINAL, FEMALE	2
9	02-307	WIRE, 2 COND, SHIELDED, 22 AWG	53"
10	02-335	SWITCH	1
11	02-336	RECEPTACLE	1
12	02-563	HEAT SHRINK TUBE, 1/8 ID	0.5"
13	04-078	RUBBER GROMMET	2
14	04-397	CORD STRAP	2
15	04-484	RUBBER BUMPER	1
16	A-0448	HANDLE SWITCH BOX COVER	1
17	294-002-027	CATCH ARM	2
18	A-1028	START SWITCH COVER	1
19	294-002-083	HANDLE WELDMENT	1

## 294-002-359 110V POWER CORD ASSEMBLY

	PART NO.	DESCRIPTION
1	04-443	Support Grip, Single Eye, Single Weave
2	02-238	Wire, 12/3, Type SJTO
3	294-002-219	Connector Body
4	02-397	125V, 20A, Male Plug

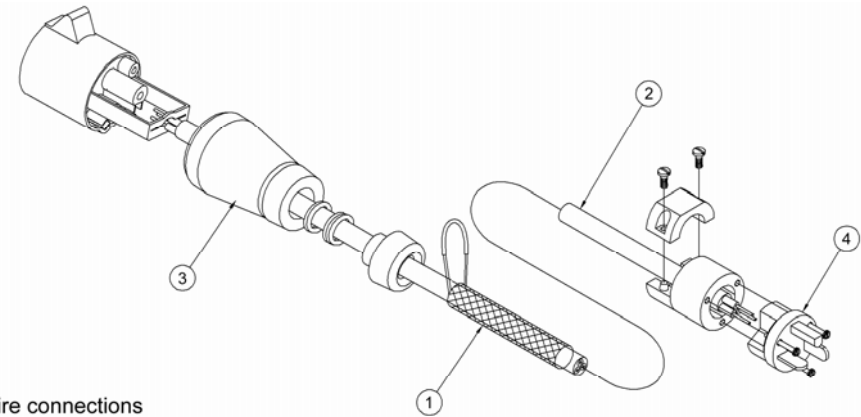

Detail for wire connections

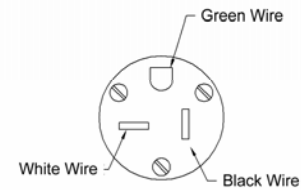
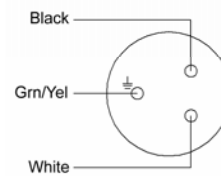

## 294-002-250 220V POWER CORD ASSEMBLY

	PART NO.	DESCRIPTION
1	294-002-219	Connector Body
2	294-002-249	Harmonized Power Cord
3	04-443	Support Grip, Single Eye, Single Weave

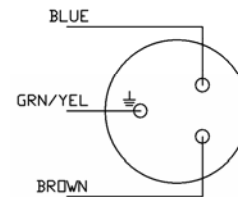
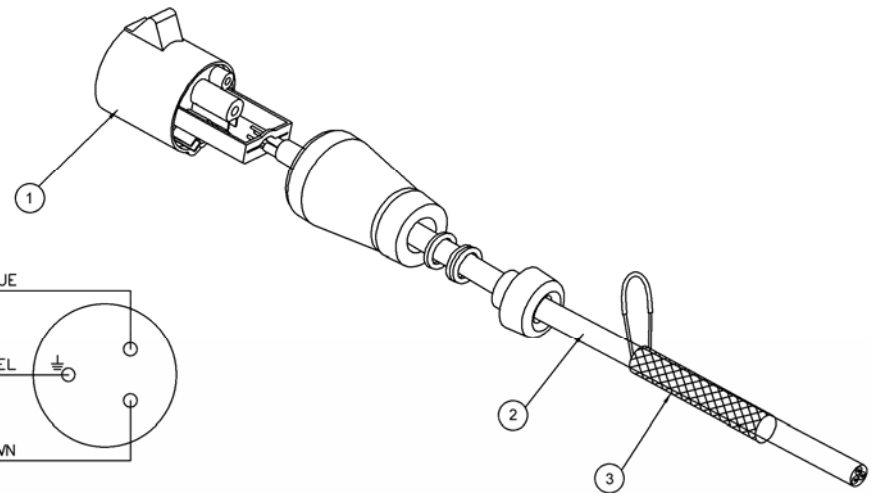

**RP-43  
BUFFER PRESSURE ADJUSTING TOOL**

	<b>NUMBER</b>	<b>DESCRIPTION</b>
1	01-108	Screw, 6-32 X 1/4 Pan Head
2	04-403	Recessed Bumper

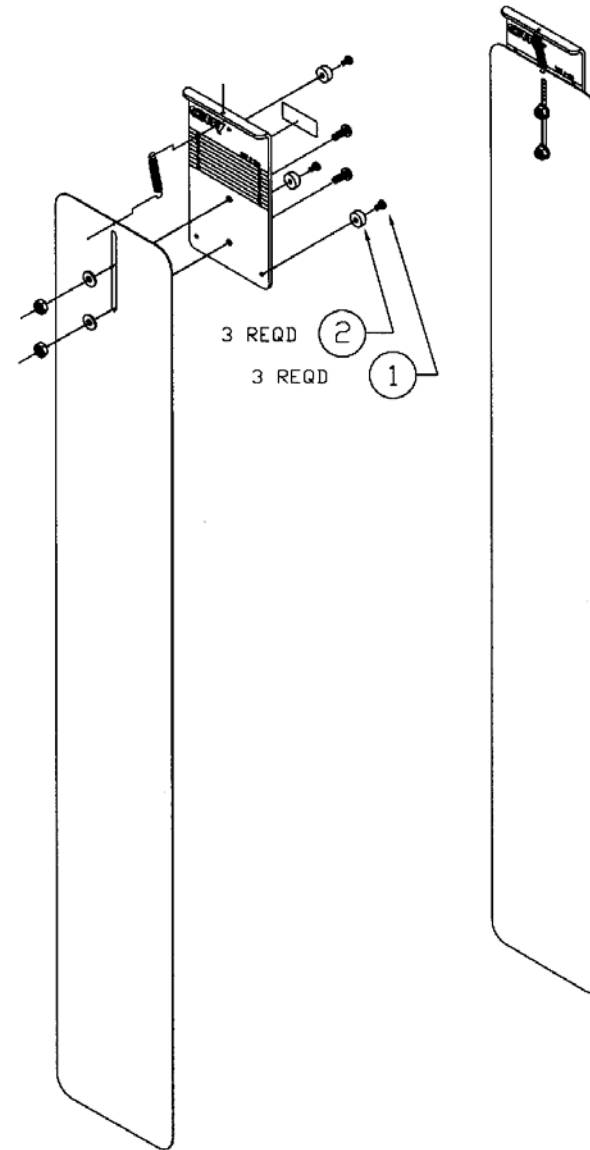

This page intentionally left blank.

**Note: Relay K1 Coil and K1 Contacts are the same relay, shown for simplicity. This relay is mounted on the Front Panel, by the Fluid Pump.**

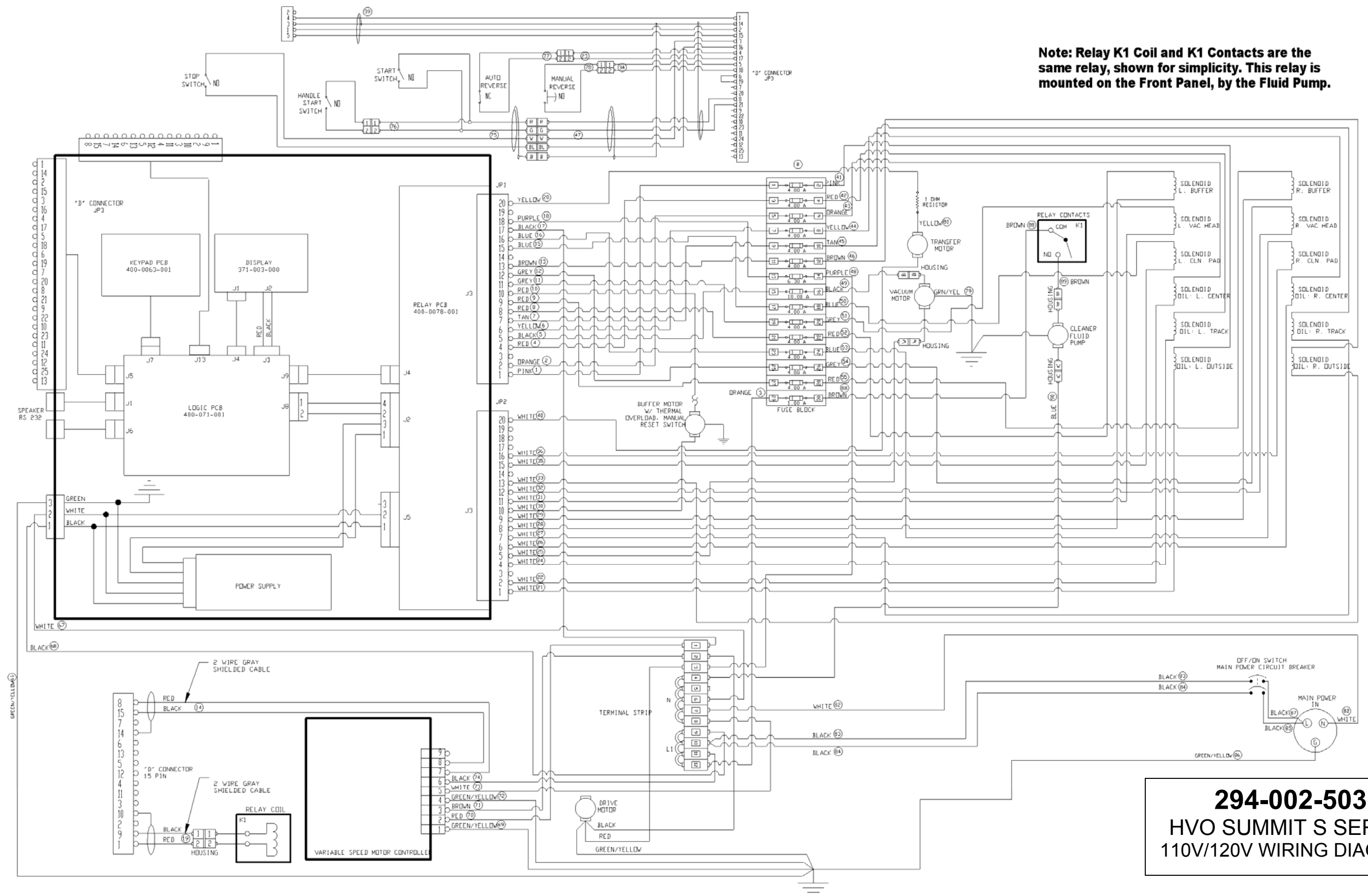

**294-002-503**  
**HVO SUMMIT S SERIES**  
**110V/120V WIRING DIAGRAM**

**Note: Relay K1 Coil and K1 Contacts are the same relay, shown for simplicity. This relay is mounted on the Front Panel, by the Fluid Pump.**

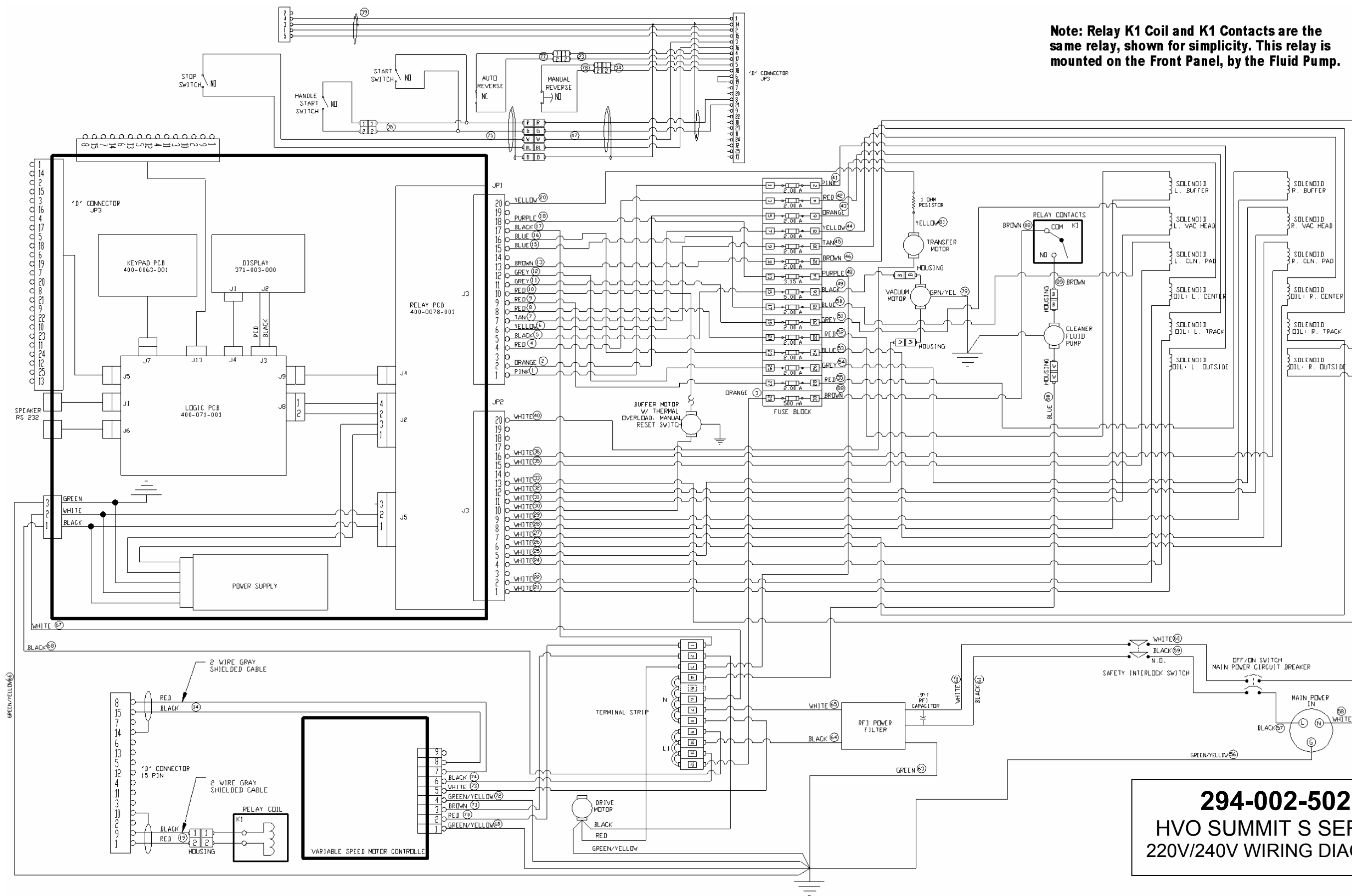

**294-002-502**  
**HVO SUMMIT S SERIES**  
**220V/240V WIRING DIAGRAM**



# Index of Part Numbers

01-001, 11, 31	01-066, 13	01-352, 61
01-005, 11	01-070, 13	01-355, 71
01-006, 27	01-077, 75	01-385, 9
01-007, 7	01-078, 13, 63, 75	01-392, 13
01-008, 15, 32, 33	01-080, 11, 17	01-402, 15
01-009, 23, 25, 27, 37, 59	01-082, 63	01-416, 75, 77
01-010, 69	01-087, 63	01-476, 47
01-015, 69	01-089, 77	01-495, 11
01-016, 37, 59, 67, 69	01-093, 73	01-569, 61
01-019, 7, 19, 39, 51, 53, 55, 67	01-098, 27	01-586, 27
01-021, 9, 39, 59, 67, 69	01-108, 81	01-608, 17
01-023, 9	01-109, 27	01-618, 69
01-024, 39	01-115, 11, 59	02-008, 11
01-025, 13, 15	01-122, 9	02-013, 67, 69
01-027, 71	01-130, 3, 5, 9, 79	02-015, 59
01-029, 15, 31	01-135, 11	02-016, 59
01-030, 41, 67	01-136, 15	02-023, 75
01-031, 9, 11	01-148, 56	02-038, 59
01-032, 9, 15, 47	01-152, 79	02-067, 75
01-033, 7, 9, 13, 17, 39, 59, 67, 69	01-155, 13	02-078, 59
01-036, 11, 13, 73	01-159, 9, 13, 37	02-086, 67
01-038, 17	01-162, 51, 53, 55	02-206, 41
01-040, 11, 51, 53, 55	01-174, 29	02-208, 79
01-041, 28, 39, 61	01-178, 69	02-214, 37
01-044, 9, 11, 37, 39, 43, 59, 67	01-186, 53, 55	02-238, 80
01-046, 9, 13, 37, 39, 59, 77	01-195, 75	02-255, 37
01-048, 9, 13, 37, 59	01-197, 9	02-293, 15
01-051, 17, 37, 77	01-214, 11	02-299, 79
01-052, 9, 73, 77	01-215, 11	02-307, 79
01-053, 11, 71	01-229, 47	02-309, 65
01-054, 9, 11, 13, 37, 43, 59, 67, 77	01-253, 77	02-335, 15, 79
01-056, 11, 17, 59	01-298, 65	02-336, 79
01-058, 79	01-302, 67	02-397, 80
01-059, 59	01-303, 79	02-539, 71
01-063, 59	01-310, 79	02-563, 79
01-065, 13, 61	01-337, 13	02-767, 59

# Index of Part Numbers

02-770, <b>61</b>	294-002-018, <b>7</b>	294-002-249, <b>80</b>
02-786, <b>61</b>	294-002-019, <b>7</b>	294-002-252, <b>71</b>
03-001, <b>27</b>	294-002-020, <b>7, 17, 21, 24</b>	294-002-253, <b>71</b>
03-004, <b>63</b>	294-002-025, <b>59</b>	294-002-254, <b>71</b>
03-007, <b>27</b>	294-002-027, <b>79</b>	294-002-268, <b>28</b>
03-099, <b>37</b>	294-002-028, <b>77</b>	294-002-270, <b>28, 59</b>
03-108, <b>61</b>	294-002-029, <b>77</b>	294-002-274, <b>11</b>
04-004, <b>73</b>	294-002-031, <b>19</b>	294-002-275, <b>11</b>
04-015, <b>27</b>	294-002-032, <b>11</b>	294-002-276, <b>19</b>
04-069, <b>9</b>	294-002-033, <b>11</b>	294-002-279, <b>69</b>
04-074, <b>9</b>	294-002-060, <b>3, 5</b>	294-002-324, <b>71</b>
04-078, <b>79</b>	294-002-064, <b>20</b>	294-002-325, <b>71</b>
04-093, <b>23, 25, 35</b>	294-002-070, <b>26, 37</b>	294-002-326, <b>71</b>
04-112, <b>41</b>	294-002-078, <b>67</b>	294-002-327, <b>71</b>
04-120, <b>37</b>	294-002-082, <b>59</b>	294-002-350, <b>28, 59</b>
04-128, <b>41, 45</b>	294-002-083, <b>79</b>	294-002-356, <b>13</b>
04-149, <b>57</b>	294-002-085, <b>9</b>	294-002-359, <b>80</b>
04-150, <b>57</b>	294-002-087, <b>59</b>	294-002-401, <b>39</b>
04-292, <b>9, 13</b>	294-002-120, <b>59</b>	294-002-402, <b>39, 41</b>
04-322, <b>41, 45</b>	294-002-134, <b>75</b>	294-002-403, <b>39</b>
04-323, <b>2, 3, 5</b>	294-002-136, <b>9, 74</b>	294-002-404, <b>39</b>
04-332, <b>9, 13</b>	294-002-148, <b>27</b>	294-002-405, <b>39</b>
04-342, <b>35</b>	294-002-149, <b>27</b>	294-002-406, <b>39</b>
04-351, <b>35</b>	294-002-174, <b>17</b>	294-002-407, <b>39</b>
04-352, <b>35</b>	294-002-183, <b>69</b>	294-002-410, <b>41</b>
04-397, <b>79</b>	294-002-185, <b>69</b>	294-002-413, <b>2</b>
04-398, <b>41, 45</b>	294-002-214, <b>69</b>	294-002-414, <b>4</b>
04-403, <b>81</b>	294-002-215, <b>69</b>	294-002-415, <b>76</b>
04-443, <b>80</b>	294-002-218, <b>69</b>	294-002-416, <b>77, 78</b>
04-453, <b>45</b>	294-002-219, <b>80</b>	294-002-417, <b>6, 16, 36, 77</b>
04-484, <b>79</b>	294-002-226, <b>71</b>	294-002-418, <b>7</b>
294-001-006, <b>59</b>	294-002-232, <b>71</b>	294-002-419, <b>9, 73</b>
294-001-007, <b>17</b>	294-002-237, <b>71</b>	294-002-420, <b>58, 66</b>
294-001-410, <b>43</b>	294-002-238, <b>13, 70</b>	294-002-421, <b>67, 68</b>
294-002-003, <b>67</b>	294-002-240, <b>71</b>	294-002-423, <b>3</b>
294-002-011, <b>59</b>	294-002-241, <b>71</b>	294-002-424, <b>9</b>
294-002-016, <b>59</b>	294-002-246, <b>71</b>	294-002-426, <b>9</b>

# Index of Part Numbers

294-002-427, **9**  
294-002-428, **59**  
294-002-429, **9**  
294-002-430, **9**  
294-002-431, **9**  
294-002-432, **11**  
294-002-433, **11**  
294-002-434, **11**  
294-002-437, **5**  
294-002-439, **73**  
294-002-440, **69**  
294-002-441, **15**  
294-002-442, **13**  
294-002-443, **13**  
294-002-444, **13**  
294-002-445, **9**  
294-002-446, **9**  
294-002-447, **9**  
294-002-448, **39, 41**  
294-002-449, **39**  
294-002-453, **41**  
294-002-458, **9**  
294-002-462, **6, 16, 36**  
294-002-464, **58, 66**  
294-002-467, **3**  
294-002-480, **53, 55**  
294-002-481, **37, 54**  
294-002-482, **37, 52**  
294-002-505, **67**  
294-010-001, **25**  
294-115-048, **41, 43**  
294-115-071, **41**  
294-115-072, **39, 41, 43**  
294-115-073, **39, 41**  
294-115-074, **41, 43**  
294-115-076, **41**  
294-115-092, **41, 43**

294-115-269, **80**  
294-115-287, **41**  
294-115-288, **41**  
294-115-404, **63**  
711-504-046, **9**  
711-504-047, **9**  
770-013-043, **71**  
809-068-327, **9**  
810-349-200, **79**  
812-027-100, **77**  
835-540-002, **31**  
835-549-002, **59**  
838-740-002, **41**  
880-164-720, **41**  
945-546-900, **59**  
948-975-172, **39**  
951-148-002, **39, 61**  
951-632-060, **23, 25, 27**  
957-100-002, **19**  
964-572-000, **59**  
A-0031, **9**  
A-0036, **27**  
A-00371, **13**  
A-0041, **63**  
A-0071, **27**  
A-0073, **59**  
A-0079, **32**  
A-0109, **15**  
A-0113, **15**  
A-0148, **9**  
A-0271, **51, 53, 55**  
A-0337, **63**  
A-0338, **37**  
A-0341, **9**  
A-0342, **9**  
A-0343, **9**  
A-0344, **11**

A-0353, **75**  
A-0355, **75**  
A-0356, **75**  
A-0403, **17**  
A-0405, **37**  
A-0406, **37**  
A-0408, **17**  
A-0409, **32, 33**  
A-0420, **29**  
A-0425, **28**  
A-0444, **77**  
A-0445, **15**  
A-0448, **79**  
A-0453, **77**  
A-0463, **27**  
A-0464, **27**  
A-0468, **59**  
A-0521, **63**  
A-0580, **77**  
A-0583, **27**  
A-0586, **9**  
A-0588, **9**  
A-0603, **17**  
A-0659, **9**  
A-0674, **19**  
A-0784, **49**  
A-0794, **9, 13**  
A-0855, **61**  
A-0875, **7**  
A-0881, **23**  
A-0882, **23**  
A-0884, **7**  
A-0885, **17**  
A-0897, **35**  
A-0898, **35**  
A-0900, **35**  
A-0901, **35**

# Index of Part Numbers

A-0902, **35**  
A-0903, **35**  
A-0919, **9**  
A-0951, **27**  
A-0952, **37**  
A-0975, **41, 45**  
A-1028, **79**  
A-1055, **51**  
A-1056, **53, 55**  
A-2037, **77**  
A-4036, **11**  
A-4037, **11**  
A-4038, **11**  
A-4041, **11**  
A-4044, **11**  
A-4045, **11**  
A-4055, **11**  
A-5038, **17**  
A-5061, **31**  
A-5546, **32, 33**  
A-5547, **9**  
A-5554, **31**  
A-5555, **31**  
A-5556, **31**  
A-5557, **31**  
A-5558, **31**  
A-5574, **77**  
A-8011, **63**  
A-8249, **65**  
A-8284, **53, 55**

A-8285, **53, 55**  
A-8307, **37**  
A-8308, **56**  
A-8328, **11**  
A-8329, **51**  
A-8331, **59**  
A-8340, **47**  
A-8346, **41**  
B-0063, **27**  
B-0107, **15**  
B-0111, **72**  
B-0505, **9**  
B-5012, **77**  
B-8032, **49**  
C-0776, **49**  
C-8341, **56**  
RP-43, **81**  
SA-0033B, **59**  
SA-0175, **9**  
SA-0176, **9**  
SA-0210, **17, 22**  
SA-0210C, **7, 21**  
SA-0210G, **7, 21**  
SA-0213, **23, 25**  
SA-0250, **67**  
SA-0255, **49**  
SA-0256, **37, 48**  
SA-0257, **61**  
SA-0259, **59, 60**  
SA-0260, **67**

SA-0279, **59, 62**  
SA-0282, **69**  
SA-0283, **47**  
SA-0291, **59, 60**  
SA-0296, **27**  
SA-0321, **37, 50**  
SA-1023L, **27**  
SA-1023R, **27**  
SA-1049, **15, 72**  
SA-1101, **37, 57**  
SA-1105, **32, 37**  
SA-1106, **33, 37**  
SA-1129, **37, 56**  
SA-1182, **29, 37**  
SA-1186, **72**  
SA-1205, **59, 64**  
SA-1227, **34**  
SA-1229, **35**  
SA-3012, **9**  
SA-3023L, **27**  
SA-3023R, **27**  
SA-3039, **17, 18**  
SA-3051, **17, 18**  
SA-6516R, **13, 30**  
SA-6534, **31**  
SA-9029, **47**  
SA-9032, **37, 46**  
SV-21, **47**  
SV-A4, **47**